



STD and StandardFLEX
VISE

GERARDI Focus



MULTIFLEX VISE



FMS VISE



MULTITASKING VISE



ZERO POINT



TOMBSTONES /
PALLETS / BASE PLATES



ANGLE HEADS



DRIVEN TOOLS

DISCOVER OTHER
PRODUCTS INSIDE!!

THE HISTORY

The first Italian company to design and develop a complete steel modular workholding system which Guaranteed international worldwide success!



1971 Gerardi S.p.A. Co. was established by Ivano Gerardi Sr. in 1971 with a background of 20 years experience in all kinds of machine shops throughout Canada and U.S.A. Today the company is located just 5 Km far from the Milan International Airport Malpensa 2000.



1980 In the Eighties the company grows to become the largest Italian vise manufacturer and one of the leaders in the European Common Market and the quality of its products gains worldwide renown. Meanwhile the company develops its own Grinding machines with a totally new concept at the base of the project. Moreover Gerardi S.p.A. launches a wide range of Angle Heads for traditional machine tools and machining centers and Driven Tools for C.N.C. lathes. With worldwide marketing efforts, the company has brought the production from few pieces to thousands with products and technologies known and sold all over the world.



1990 The research and development of the grinding technologies have never stopped. In the same period the company established a joint-venture in China for the manufacturing of parts and types of vises together with the Chinese aerospace industry. Thanks to major investments the new company is today fully controlled by Gerardi and is achieving the same excellent leadership results in Asia as those accomplished in Europe.



2000 After the set up of a US subsidiary Co. near Chicago (Huntley - IL), a new German branch has been established in Stuttgart / Germany in 2007 in order to better penetrate and service the local market. Of course this meant a huge financial effort and investment, but the fast evolution and continuous adjustment to high competitive markets has always been the main Gerardi S.p.A. feature.

2012 Gerardi sets up a new manufacturing plant in LONATE POZZOLO to increase the Angle Heads and Driven Tools production and a new company in INDIA for the manufacturing of fixtures for the Indian market.

2020 The Gerardi S.p.A. Co. staff now numbers over 200 employees with an average age of under 40. In the company all the top roles and manager positions were acquired through internal training and experience geared to develop individual skills and abilities. Our total export is today more 70% of our total production in more than 60 countries around the world and we invest about 10% of our total turnover in advanced technological research for new products. The overall investments of the company exceed 20 Million.



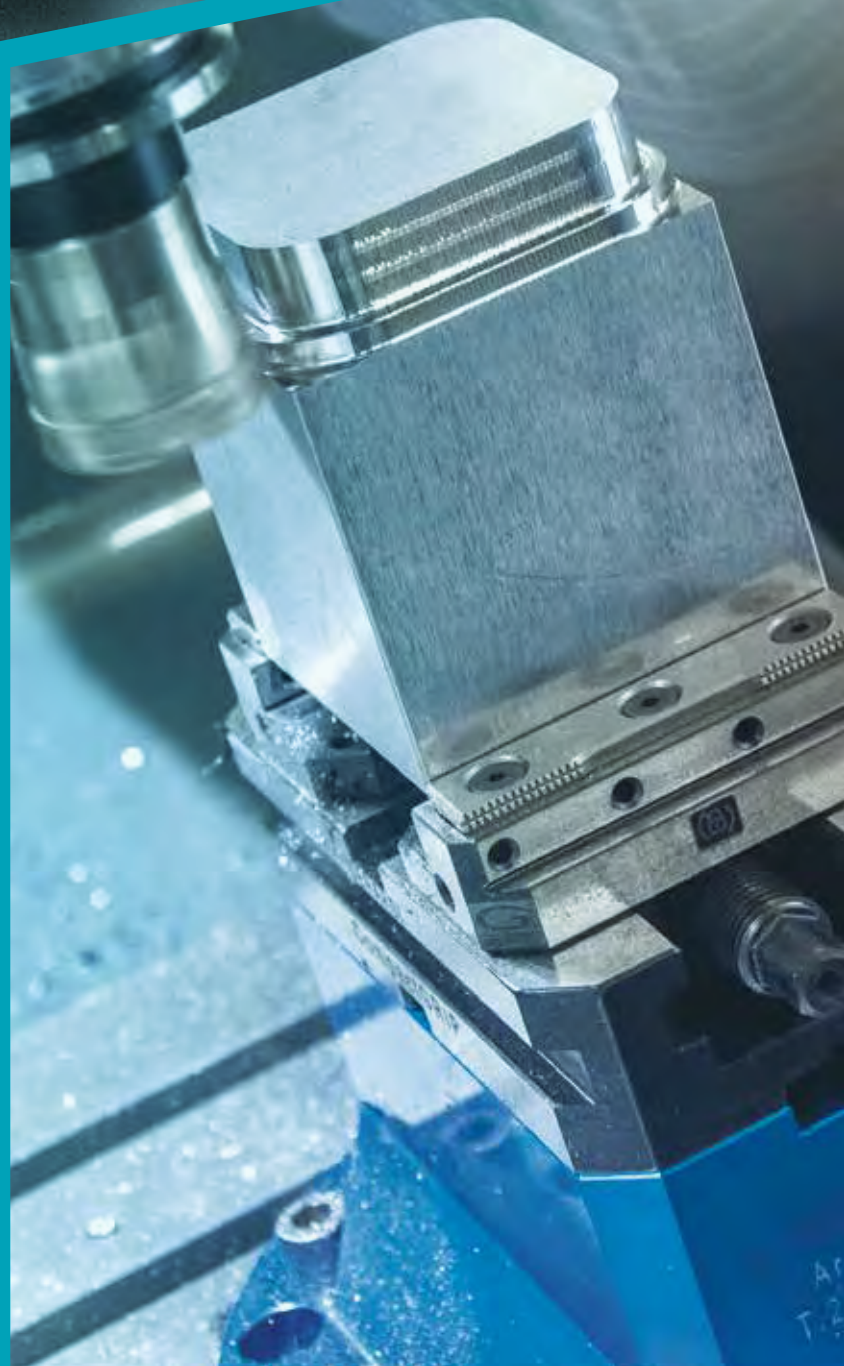
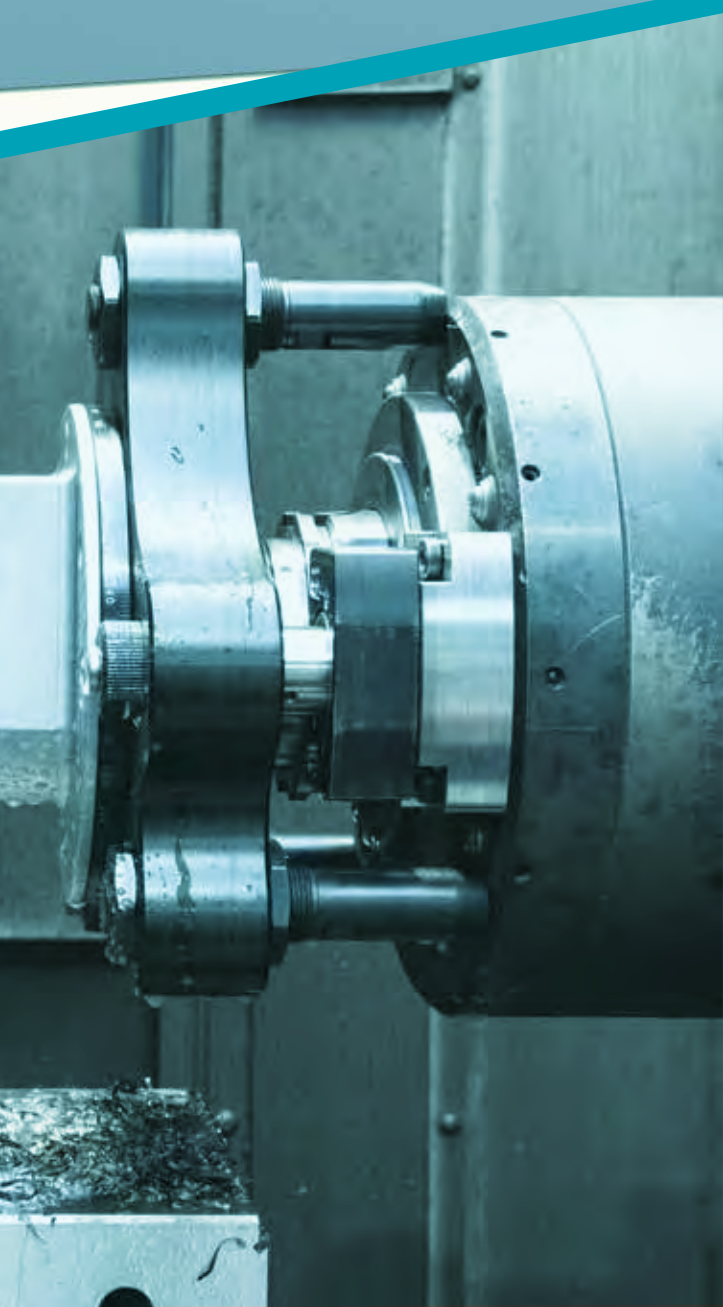
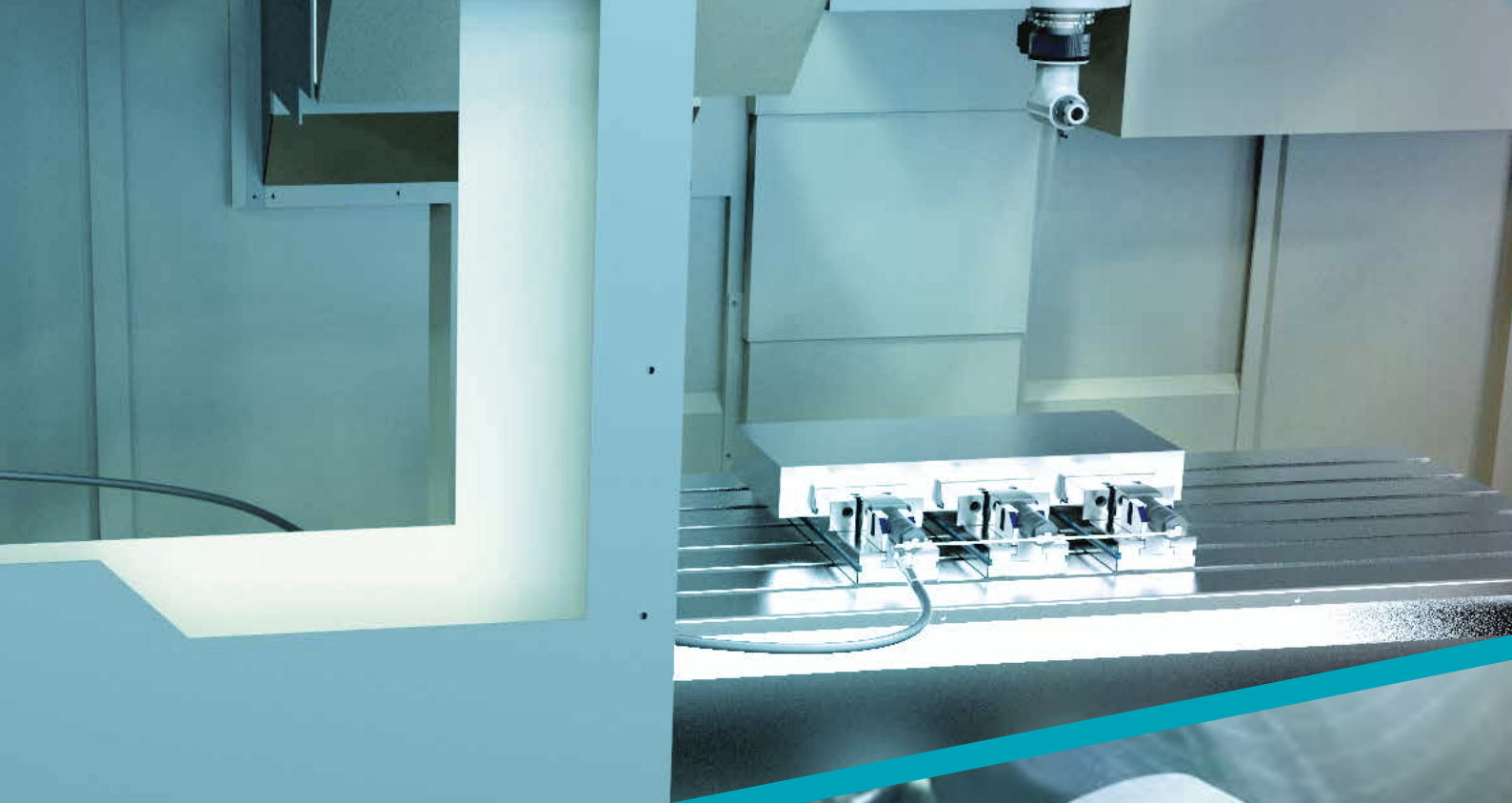

SELF-CENTERING AUTOMATIC VISE



Standard equipment:

- 4x Calibrated screws (Art.83)
- Centering pin (Art.670P)
- Direct input adaptor Air or Oil (Art.670IDL)
- Noreturn valve (Art.PN16)

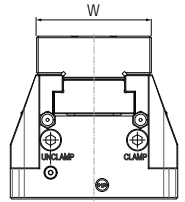
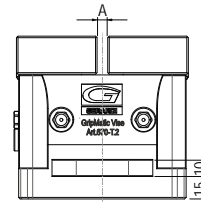

Vise Size	2	3	4
Jaw Width W	74	99	124
Max Stroke A	6,4	8,5	12
Vise Height	105	135	165
Base Height	80	105	130
Base Width	106	166	206
Centering holes pitches	90	140	170
ORDER CODES	7.67.OPN20	7.67.OPN30	7.67.OPN40
ORDER CODES	7.67.OID20	7.67.OID30	7.67.OID40

PNEUMATIC GRIPMATIC VISE

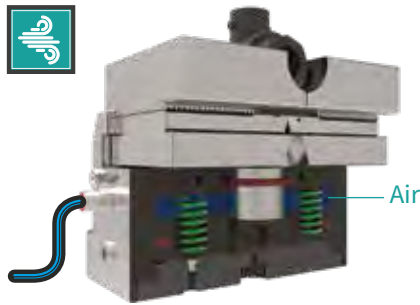

Pneumatic Vise	2	3	4
Air pressure input (BAR)	Clamping Force (kN)	Clamping Force (kN)	Clamping Force (kN)
7	4,1	12	16
8	4,5	14	18
9	4,9	15	20
10	5,1	16	22

HYDRAULIC GRIPMATIC VISE

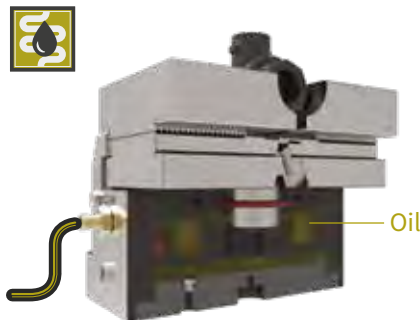

Hydraulic Vise	2	3	Hydraulic Vise	4
Oil pressure input (BAR)	Clamping Force (kN)	Clamping Force (kN)	Oil pressure input (BAR)	Clamping Force (kN)
10	4,2	14	10	24
15	6,4	20	15	29
20	8,5	24	20	36
25	10,7	28	25	43
30	12,8	32	-	-

JAWS AND JAW PLATES FOR GRIPMATIC VISES



Movable jaws

	ART.671A	Vise SIZE (W)		
		2	3	4
Soft movable jaw		7.67.1A200	7.67.1A300	7.67.1A400
NOT HARDENED				
Soft narrow movable jaw	ART.671B	7.67.1B200	7.67.1B300	7.67.1B400
NOT HARDENED				
Soft movable jaw for width standard jaw plates	ART.671C	7.67.1C200	7.67.1C300	7.67.1C400
NOT HARDENED				

Jaw plates

	ART.243	Vise SIZE (W)		
		2	3	4
Hardened grooved straight jaw plate		1.65.17000	1.65.27000	1.65.37000
Hardened smooth straight jaw plate	ART.245	4.24.51000	4.24.52000	4.24.53000
Straight plate with GRIP inserts	ART.247G	1.24.7G100	1.24.7G200	1.24.7G300

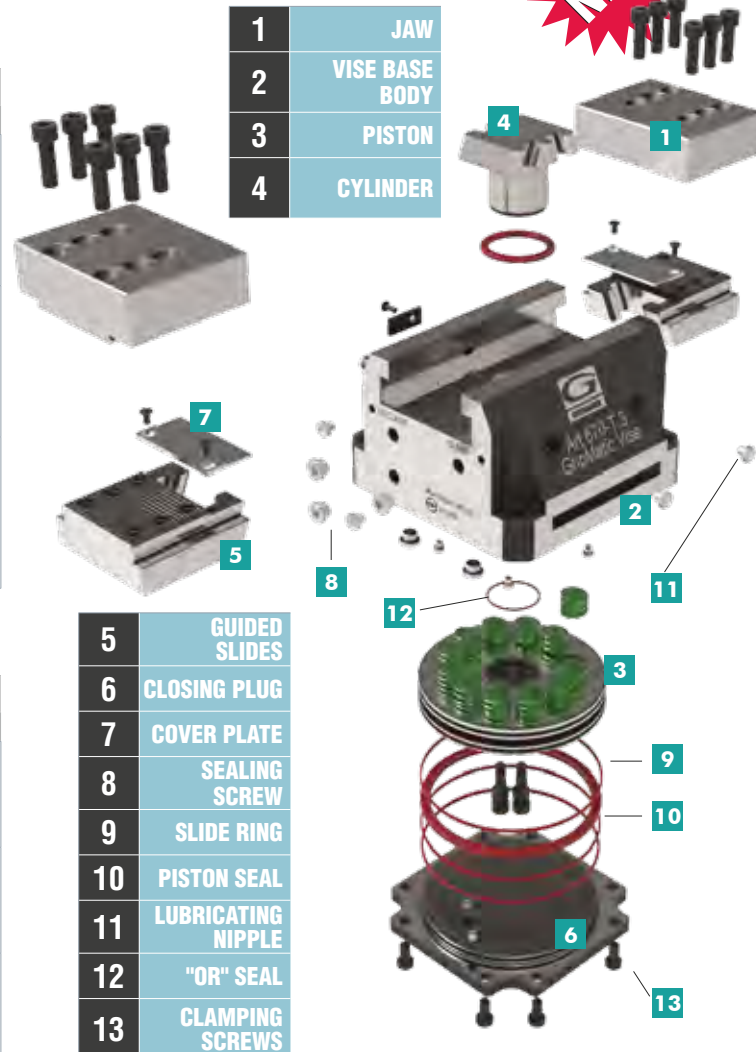

Art.670

The following diagrams give the clamping force that can be obtained with each vise type (size 2 to 4) depending on the air/oil pressure. Some factor as lubrication, type of clamping on the machine table, frictions and more can modify above values within a $\pm 10\%$ range. For optimum operation do not exceed chart values.

T.2 Hydraulic cylinder $\varnothing 85\text{mm}$
Effective surface 51,8mm²

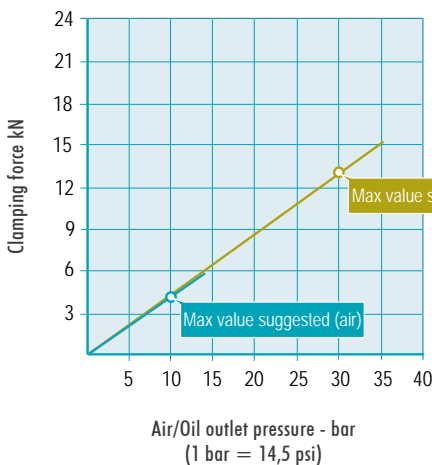

T.3 Hydraulic cylinder $\varnothing 135\text{mm}$
Effective surface 132,3mm²

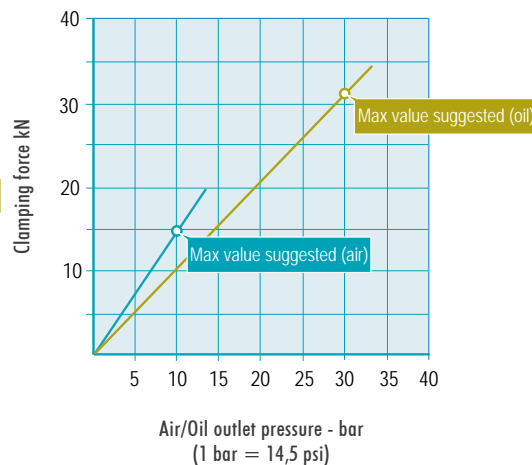

T.4 Hydraulic cylinder $\varnothing 170\text{mm}$
Effective surface 209,5mm²

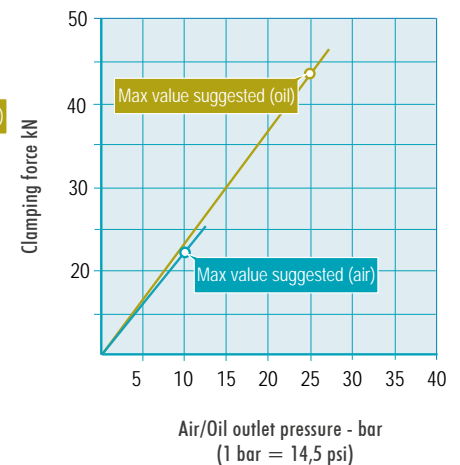

COMPACT, RIGID and ACCURATE



Compact Grip Reversible jaw inserts

For standard workpieces hardness

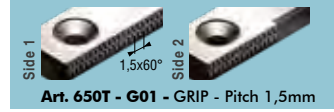

For hardened workpieces

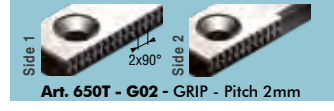

For soft material

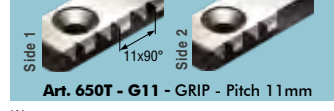

For soft material clamping and final machining

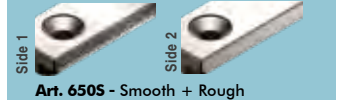

Best workpiece clamping

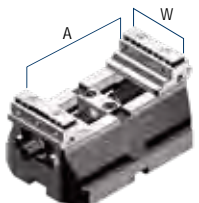
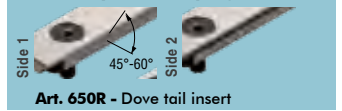

Type 1x120

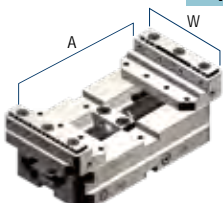

Type 2x160

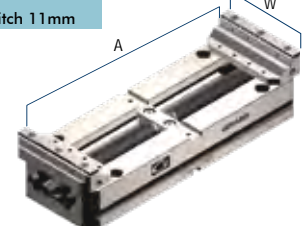

Type 3x310

Vise Size	1			2				3				
Jaw Width W	50			88				123				
Max Opening A	54	94	134	96	136	176	216	133	183	233	283	333
Vise Height	65			65				89				
Base Height	45			38				57				
Base Width	80			90				125				
Base Length	80	120	160	120	160	200	240	160	210	260	310	360
Pull Stud Pitches	52			52				96				
ORDER CODES	7.65.01080	7.65.01120	7.65.01160	7.65.02120	7.65.02160	7.65.02200	7.65.02240	7.65.03160	7.65.03210	7.65.03260	7.65.03310	7.65.03360

INTERMEDIATE JAW FOR COMPACT GRIP VISES

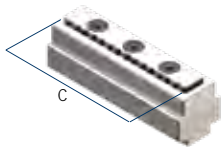
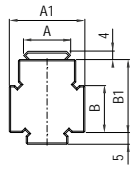
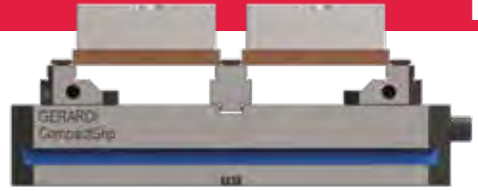

Art. 650X
intermediate fixed jaws

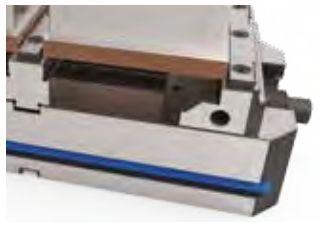
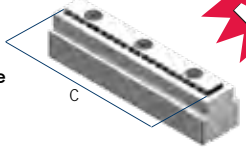

Vise Size	2				3			
A	22				22			
A1	28				29			
B	13				18			
B1	23				28			
C	88				123			
ORDER CODES	7.65.0X2000				7.65.0X3000			

ALLUMINIUM RISERS FOR COMPACT GRIP VISES ART.650

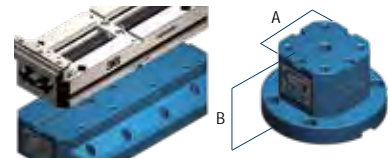

Art. 651H T.1
Simple risers

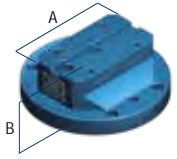

Art. 651H T.2
Simple risers

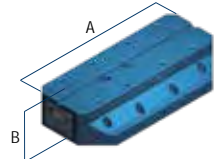

Art. 651H T.3
Simple risers

B	Vise Size	1				2				3				
	Base length A	80	120	160	120	160	200	240	160	210	260	310	360	
Height	50	ORDER CODES	7.65.1H108/50	7.65.1H112/50	7.65.1H116/50	7.65.1H212/50	7.65.1H216/50	7.65.1H220/50	7.65.1H224/50	7.65.1H316/50	7.65.1H321/50	7.65.1H326/50	7.65.1H331/50	7.65.1H336/50
	75	ORDER CODES	7.65.1H108/75	7.65.1H112/75	7.65.1H116/75	7.65.1H212/75	7.65.1H216/75	7.65.1H220/75	7.65.1H224/75	7.65.1H316/75	7.65.1H321/75	7.65.1H326/75	7.65.1H331/75	7.65.1H336/75
	100	ORDER CODES	7.65.1H108/100	7.65.1H112/100	7.65.1H116/100	7.65.1H212/100	7.65.1H216/100	7.65.1H220/100	7.65.1H224/100	7.65.1H316/100	7.65.1H321/100	7.65.1H326/100	7.65.1H331/100	7.65.1H336/100

THE MODULAR MAGNETIC PALLET with ZERO POINT SYSTEM INTEGRATED



Standard Equipment

- Electro-permanent magnetic plate - Monolithic technology and full metallic surface.
- N.2 calibrated holes + N.2 holes to fix the plate on the table
- Grid with hardened steel precision bushings
- N.2 Art.87A Zero Point positioning units
- N.2 Art.87B Complete support turrets
- Circular Mobile pole chucks set RMP 70/45 double effect
- Electronic XT200 control unit safety connector.
- Incorporated digital pushbutton board for MAG/DEMAG cycles
- Discharging reinforced cable with oil-proof PVC coating (5M length)
- Power supply cable, length 4M (without connecting pin)

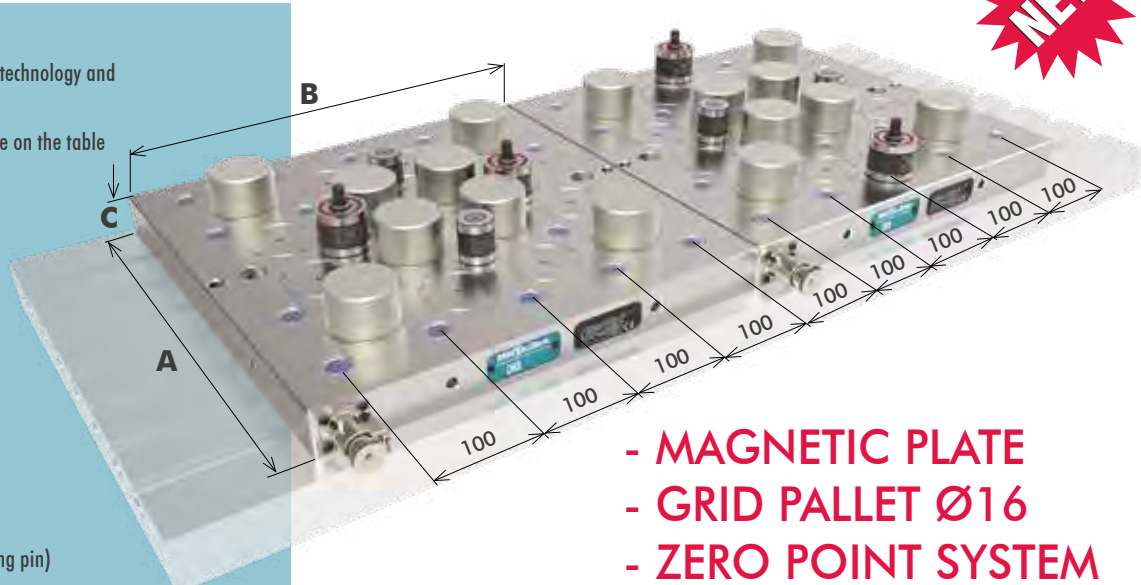

- MAGNETIC PLATE
- GRID PALLET Ø16
- ZERO POINT SYSTEM

For Cast Iron / Steel (Fe370 or C40)		For Alloyed steel as (38NiCrMo5 or 16MnCr5)		Dimension			Chuck	Force	Weight	RMP	Art.87A	Art.87B
ORDER CODES	* Force (Ton)	ORDER CODES	*Force (Ton)	A	B	C	(n)	Kgf	(Kg)	(n)	(n)	(n)
1088ZP4040.K01	5,8	1088ZP4040.K01N	2,9	400	400	51	9	652	95	6	2	2
1088ZP5050.K01	10,4	1088ZP5050.K01N	5,2	500	500	51	16	652	125	8	2	2
1088ZP6060.K01	13,7	1088ZP6060.K01N	6,85	600	600	51	21	652	160	12	2	2

POWER UNIT XT 200



Voltagges and Frequency 50 / 60 Hz to be specified on the order

Voltage	ORDER CODES	Notes
200V	V1	Connector ERGON
230V	V2	
380/440V	V3	
460/480V	V4	

OPTIONS

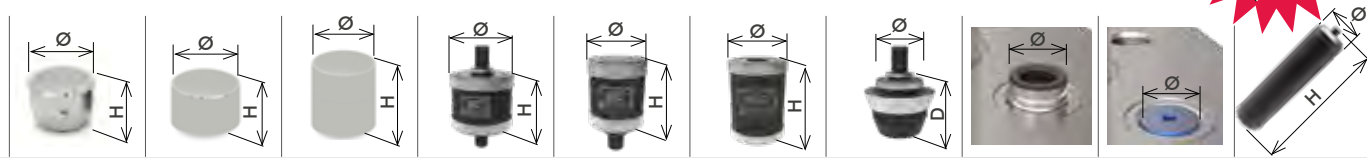

	RMP 70/45	PRF 70/45	PFR 70/75	Art.87A	Art.87B	Art.87C	Art.87AC	Art.87AD	Art.87BB	Art.87ZPB
	Circular Mobile pole chuck	Fixed pole chuck	Pole chuck extension	Zero Point positioning unit	Complete support turret	Extension	Conical Pull Stud	Extra bushing	Aluminum bushing cap	Plug extractor
H	45	45	75	45	45	75	24	-	-	81
Ø	70	70	70	54	39	54	20	20 G5	20 H7	20,5
kg	1,3	0,5	0,8	0,8	1,9	1,2	0,06	0,1	0,004	0,19
ORDER CODES	RMP_70-45	PRF_70-45	PRF_70-75	1087A5445	1087B3945	1087C5475	1087AC5445	1087AD5445	1087BB0020	1088ZPB5050

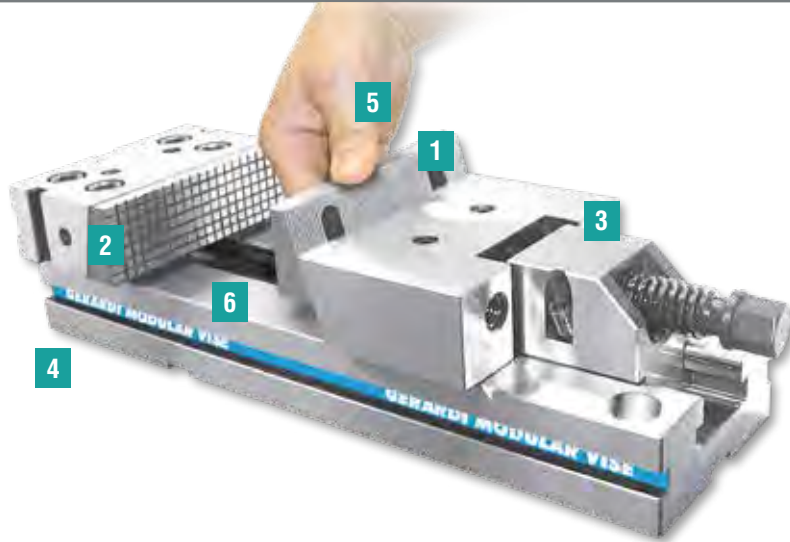

Supplied with Gerardi StandardFLEX Machine Vise:

- 1x workstop ART.370
- 1x pair of positioning keys (16mm)
- 1x box wrench ART.375
- 1x T wrench ART.376
- 2 Plugs ART.291



Endless Clamping Possibilities!

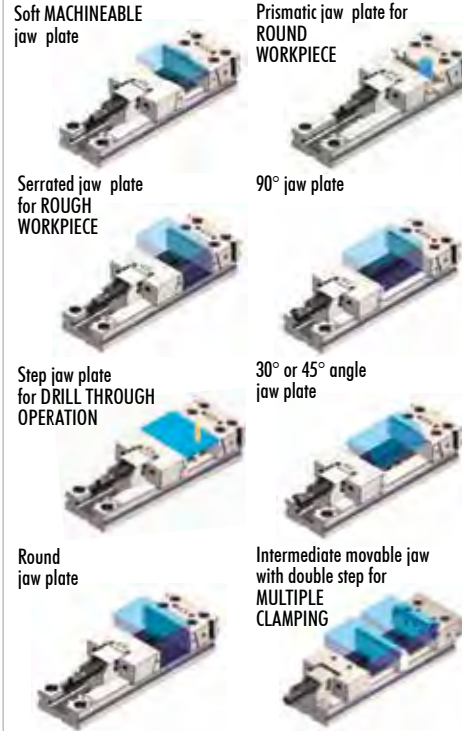

1	MODULAR	The world's largest range of modular accessories means clamping almost ANYTHING is possible with Gerardi's standard jaws.
2	NO WEAR	Made 100% from high quality, case hardened HRC 60 alloyed resistance steel in order to give maximum rigidity, high performance and no wear. As evidence we give 5 YEARS WARRANTY on all the vises and mechanical components.
3	QUICK CLAMPING	Sliding movable jaw is pushed close to the work piece then fully tightened with 1/4 turn of the wrench. Also available with Hydraulic, Pneumatic, Manual hydraulic & Electrical hydraulic clamping.
4	HIGHEST ACCURACY +/-0.02mm	Every sliding and working surface is ground. Centesimal tolerances are guaranteed by checking cycles with CNC measuring machine. The perfect alignment with the machine axis is given by longitudinal and cross keyways (16H7)
5	QUICK HAND CHANGE JAWS	ONLY with Gerardi Standard Flex vises is it possible to change the vise jaw plates in under 5 seconds. The special comb design ensures jaw plates glide into place. All working surfaces are ground and hardened to HRC60 as standard on jaw plates.
6	BETTER PULL DOWN ACTION	Increased and better pull down straight action and better protection from chips.

Standard Flex Vises - Art.1A

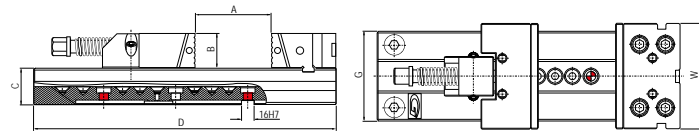

	SIZE								
	2 (25kN)		3 (30kN)		4 (30kN)			5 (40kN)	
A	150	200	300	200	300	400	200	300	400
W	121	146		171			196		
B	38	48		58			63		
C	40	50		58			70		
D	345	420	520	455	555	655	495	595	695
G	95	125		145			170		
kg	12,9	25	29	37	42	47	64	69	74
ART.1A ORDER CODES	1.1A.20000	1.1A.32000	1.1A.33000	1.1A.42000	1.1A.43000	1.1A.44000	1.1A.52000	1.1A.53000	1.1A.54000

Stack Type Jaws (Normal width)

	W	ART.	Vise SIZE (W)			
			2 (121)	3 (146)	4 (171)	5 (196)
For round parts		ART.131	2.13.12000	2.13.13000	2.13.14000	2.13.15000
For higher workpieces		ART.138	2.13.82000	2.13.83000	2.13.84000	2.13.85000
Prismatic jaw for vertical round workpieces		ART.150	1.15.02000	1.15.03000	1.15.04000	1.15.05000

Stack Type Jaws (SUPER NARROW WIDTH)

	W	ART.	Vise SIZE (W)			
			2 (94)	3 (124)	4 (144)	5 (169)
For round parts		ART.131A	2.13.1A200	2.13.1A300	2.13.1A400	2.13.1A500
For higher workpieces		ART.139	2.13.92000	2.13.93000	2.13.94000	2.13.95000
Prismatic jaw for vertical round workpieces		ART.150A	1.15.0A200	1.15.0A300	1.15.0A400	1.15.0A500

THE PERFECT MIX OF PRICE+QUALITY

Innovative comb system for quick pull-down jaw plate changes!



Standard Flex XL Single Vises - Art.20A

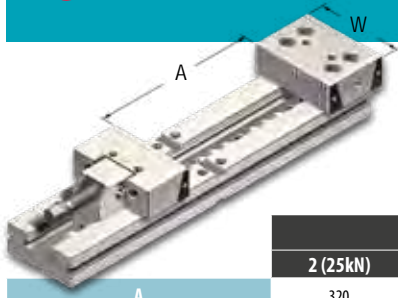

ADD 1 MOVABLE JAW TO TURN INTO A DOUBLE XL Vise



	SIZE								
	2 (25kN)		3 (30kN)		4 (30kN)		5 (40kN)		
A	320	360	460	400	500	600	600	700	900
W	121	146			171			196	
B	38	48			58			63	
C	40	50			58			70	
D	520	580	680	666	766	866	905	1005	1205
G	95	125			145			170	
kg	12.9	25.5	29	37	42	47	69	74	84
ART.20A ORDER CODES	2.20.A2320	2.20.A3360	2.20.A3460	2.20.A4400	2.20.A44500	2.20.A4600	2.20.A5600	2.20.A5700	2.20.A5900

Standard Flex XL Double Vises - Art.30A

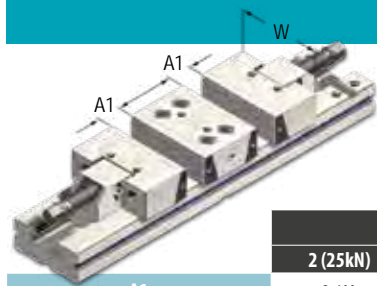

REMOVE 1 MOVABLE JAW TO TURN INTO A SINGLE XL Vise



	SIZE								
	2 (25kN)		3 (30kN)		4 (30kN)		5 (40kN)		
A1	2x100	2x110	2x160	2x120	2x170	2x220	2x200	2x250	2x350
W	121	146			171			196	
B	38	48			58			63	
C	40	50			58			70	
D	520	580	680	666	766	866	905	1005	1205
G	95	125			145			170	
kg	16.9	32.5	36	49	54	59	102	108	120
ART.30A ORDER CODES	2.30.A2100	2.30.A3110	2.30.A3160	2.30.A4120	2.30.A4170	2.30.A4220	2.30.A5200	2.30.A5250	2.30.A5350

Jaw Plates

	ART.	Vise SIZE (W)			
		2 (121)	3 (146)	4 (171)	5 (196)
Soft	ART.230B	4.23.0B201	4.23.0B301	4.23.0B401	4.23.0B501
Hard Smooth	ART.230C	4.23.0C201	4.23.0C301	4.23.0C401	4.23.0C501
Step	ART.230E	4.23.0E201	4.23.0E301	4.23.0E401	4.23.0E501
Prismatic	ART.230F	4.23.0F201	4.23.0F301	4.23.0F401	4.23.0F501
Angle	ART.230M	4.23.0M201-45	4.23.0M301-45	4.23.0M401-45	4.23.0M501-45
Intermediate Jaw with Step	ART.212	1.21.22000	1.21.23000	1.21.24000	1.21.25000

Step Jaw Plates Sets With Rack - Art.230E Set

	Vise SIZE (W)			
	2 (121)	3 (146)	4 (171)	5 (196)
H	33	43	53	53
H1	5	5	5	10
B	38	48	58	63
H1 Heights Step Jaws Included in the set	3 x2	3 x2	3 x2	3 x2
	5 x2	5 x2	5 x2	5 x2
	8 x2	8 x2	8 x2	10 x2
	13 x2	13 x2	13 x2	13 x2
	18 x2	18 x2	18 x2	18 x2
	23 x2	23 x2	23 x2	23 x2
	-	28 x2	28 x2	28 x2
ORDER CODE	4.32.0A200	4.32.0A300	4.32.0A400	4.32.0A500

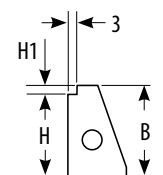

Always specify H1 DIMENSION



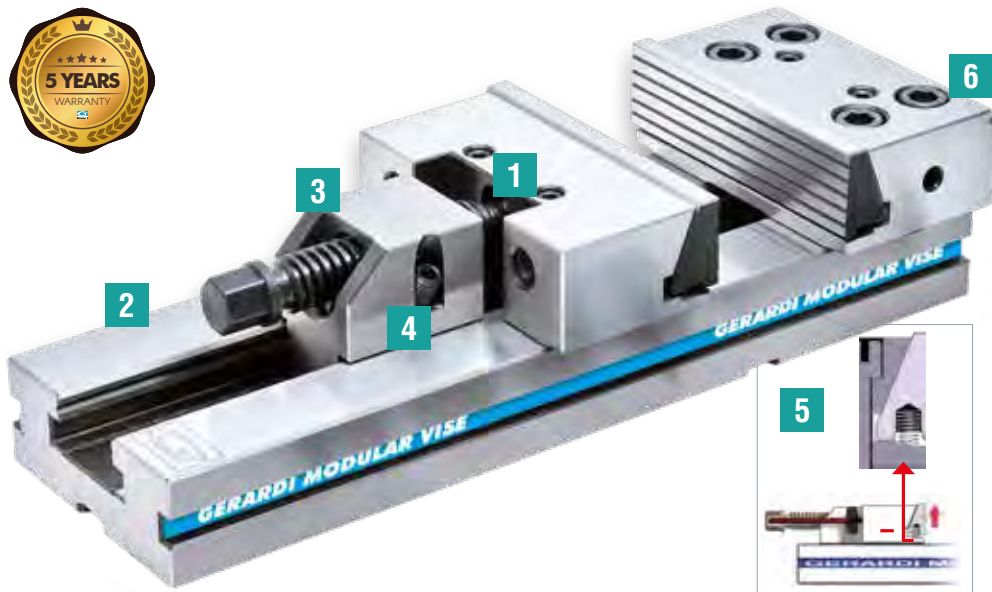

Supplied with Gerardi Standard Series Machine Vise:

- 1x workstop ART.370
- 1x pair of positioning keys (16mm)
- 1x box wrench ART.375
- 1x T wrench ART.376

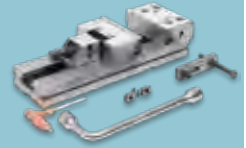

Endless Clamping Possibilities!

Solid guided movable jaw Art.127



Prismatic guided movable jaw Art.217



Floating movable jaw Art.210

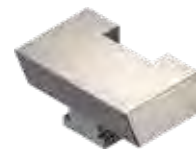

Pair of straight parallel magnetic plates Art.313



Pair of angular magnetic parallel plates Art.314



Intermediate movable jaw with double step Art.212 for MULTIPLE CLAMPING



1	MODULAR	The world's largest range of interchangeable accessories means clamping almost ANYTHING is possible with Gerardi's standard jaws.
2	NO WEAR	Made 100% from high quality, case hardened HRC 60 alloyed resistance steel in order to give maximum rigidity, high performance and no wear. As evidence we give 5 YEARS WARRANTY on all the vises and mechanical components.
3	QUICK CLAMPING	Sliding movable jaw is pushed close to the work piece then fully tightened with 1/4 turn of the wrench. NO WINDING! Also available with Hydraulic, Pneumatic, Manual hydraulic & Electrical hydraulic clamping.
4	HIGHEST ACCURACY +/-0.02mm	Every sliding and working surface is ground. Centesimal tolerances are guaranteed by checking cycles with CNC measuring machine. The perfect alignment with the machine axis is given by longitudinal and cross keyways (16H7)
5	'ON/OFF' PULL DOWN JAWS	ONLY with Gerardi Standard Series vises is it possible to change from pull down action to non-pull down action. By turning the screw 1/4 turn in the rear of the jaw, the pull-down action can be turned on or off.
6	5mm STEP ON FIXED JAW	The fixed jaw is supplied as standard with a 5mm step on the rear. Reverse the jaw and combine with ART.217 (Prismatic Jaw with Step) for through hole drilling/tapping operations.

Standard Series Vises - Art. 1

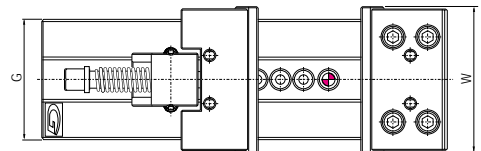
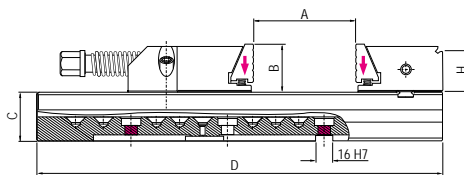

	SIZE									
	2 (25kN)			3 (30kN)			4 (30kN)			5 (40kN)
A	150	200	300	200	300	400	300	400	500	
W	125	150		175			200			
B	40	50		60			65			
C	40	50		58			70			
D	345	420	520	455	555	655	595	695	795	
G	95	125		145			170			
kg	12.9	25.5	29	37	42	47	69	74	79	
ART. 1A ORDER CODES	3.02.10000	3.03.20000	3.03.30000	3.04.20000	3.04.30000	3.04.40000	3.05.30000	3.05.40000	3.05.50000	

THE MOST POPULAR

Pull down jaws with consistent clamping & powerful clamping pressure - no need for a hydraulic vise!



Standard Series XL Single Vises - Art.21

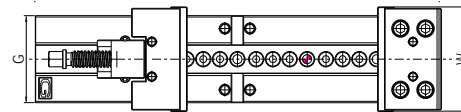
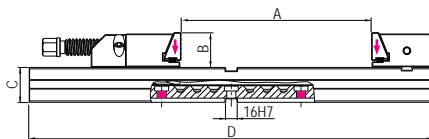

	SIZE								
	2 (25kN)	3 (30kN)		4 (30kN)			5 (40kN)		
A	320	360	460	400	500	600	600	700	800
W	125	150		175			200		
B	40	50		60			65		
C	40	50		58			70		
D	520	580	680	666	766	866	905	1005	1105
G	95	125		145			170		
kg	17	32	35	47	52	56	69	74	79
ART.20 ORDER CODES	2.21.23200	2.21.33600	2.21.34600	2.21.44000	2.21.45000	2.21.46000	2.21.56000	2.21.57000	2.21.58000

Standard Series XL Single Vises - Art.30

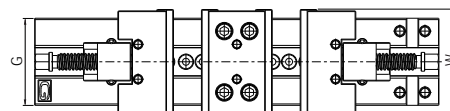
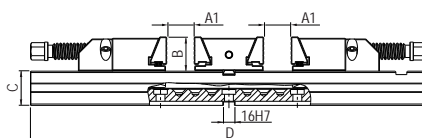

	SIZE								
	2 (25kN)	3 (30kN)		4 (30kN)			5 (40kN)		
A1	2 x 100	2 x 110	2 x 160	2 x 120	2 x 170	2 x 220	2 x 200	2 x 250	2 x 300
W	125	150		175			200		
B	40	50		60			65		
C	40	50		58			70		
D	520	580	680	666	766	866	905	1005	1105
G	95	125		145			170		
kg	21	39	43	59	64	69	102	108	114
ART.30 ORDER CODES	3.32.10600	3.33.20600	3.33.30600	3.34.20600	3.34.30600	3.34.40600	3.35.30600	3.35.40600	3.35.50600

Jaws & Jaw plates

	ART.	VISE SIZE (W)			
		2 (125)	3 (150)	4 (175)	5 (200)
Soft	ART.230	1.65.20000	1.65.30000	1.65.40000	1.65.50000
Hard Smooth	ART.232	1.65.20100	1.65.30100	1.65.40100	1.65.50100
Wedge Jaw	ART.210	2.21.02000	2.21.03000	2.21.04000	2.21.05000
Prismatic Jaw With Step	ART.217	2.21.72000	2.21.73000	2.21.74000	2.21.75000
Angle Plate	ART.314	4.31.42000-45	4.31.43000-45	4.31.44000-45	4.31.45000-45
Intermediate Jaw with Step	ART.212	1.21.22000	1.21.23000	1.21.24000	1.21.25000

Magnetic parallel plates Art.313

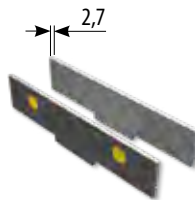

	Vise SIZE (W)			
	2 (125)	3 (150)	4 (175)	5 (200)
Width	125	150	175	200
Height	33	43	53	53
ORDER CODE	4.31.32000-33	4.31.33000-43	4.31.34000-53	4.31.35000-53

Magnetic Parallel Plate Sets* - Art.310 (6 Pairs)

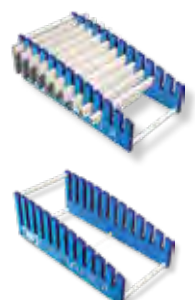

	Vise SIZE (W)			
	2 (125)	3 (150)	4 (175)	5 (200)
Width	125	150	175	200
Parallel Plates (Height) Included In The Set *Rack not included	15	25	35	35
	20	30	40	40
	25	35	45	45
	30	40	50	50
	35	45	55	57
	37	47	57	60
ORDER CODE PLATE SET	4.31.02000	4.31.03000	4.31.04000	4.31.05000
ORDER CODE RACK	4.31.72000	4.31.73000	4.31.74000	4.31.75000

Art.1 / 1A / 700

The following diagrams give the clamping force that can be obtained with each vise type (size 1 to 6) depending on the torque. Some factor as lubrication, type of clamping on the machine table, frictions and more can modify above values within a $\pm 10\%$ range. For optimum operation do not exceed chart values.

T.1 STD and StandardFLEX VISES TYPE

Screw M12 - Pitch 1,75m

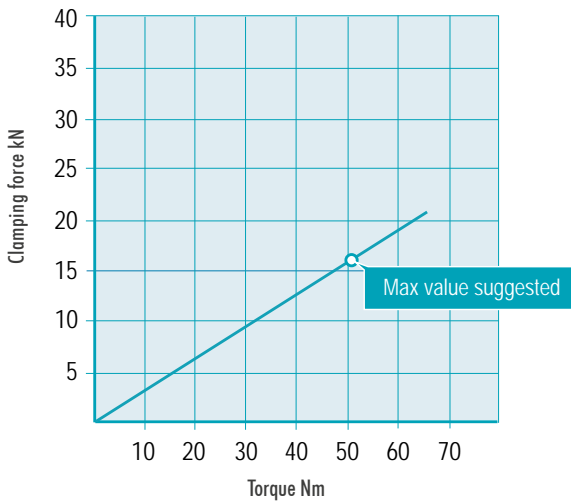

TORQUE WRENCH SUGGESTED



T.2 STD and StandardFLEX VISES TYPE

Screw TPN18 - Pitch 4mm

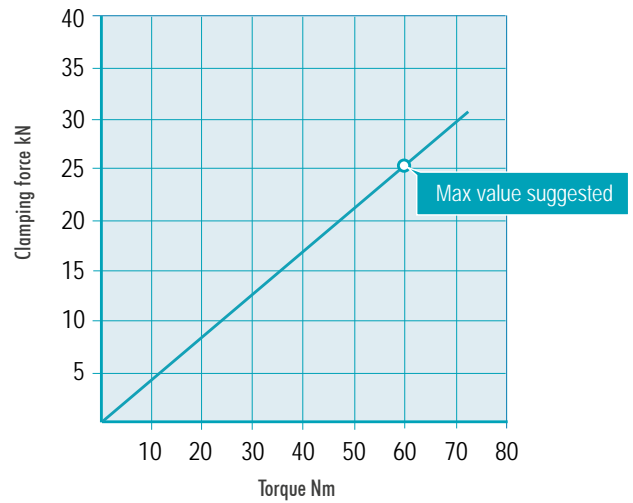

T.3-4 STD and StandardFLEX VISES TYPE

Screw TPN24 - Pitch 5mm

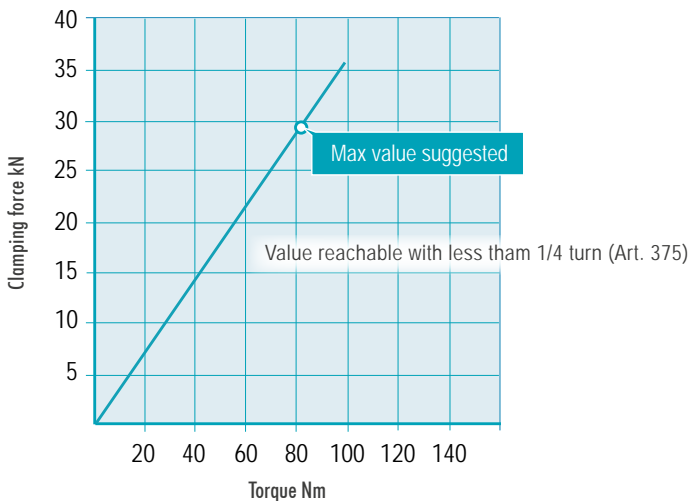

T.5-6 STD and StandardFLEX VISES TYPE

Screw TPN30 - Pitch 5mm

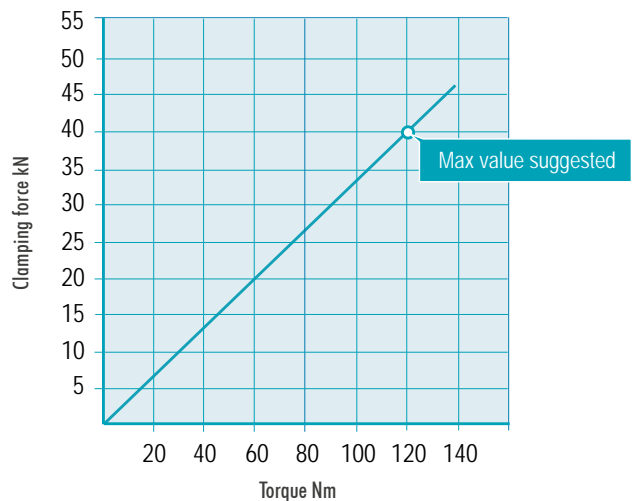

Some factor as lubrication, clamping on the machine table, frictions and more can modify above values within a $\pm 10\%$ range. For optimum operation do not exceed chart values.

Hydraulic CLAMPING

The hydropneumatic power unit for hydraulic clamping devices and its bi-products are designed to meet all needs regarding the powering of hydraulic cylinders where low flow rates and high pressures are required. The special design shape of the power unit is such that a high performance system can be implemented taking up very little space. Thanks to the special design principles, the pump section adopted allows the hydropneumatic power unit to be installed in very hostile environments, such as the work area of machine tools, etc. The unique modular hydraulic flow control system allows controlling up to 6 separate users from just the one power unit.

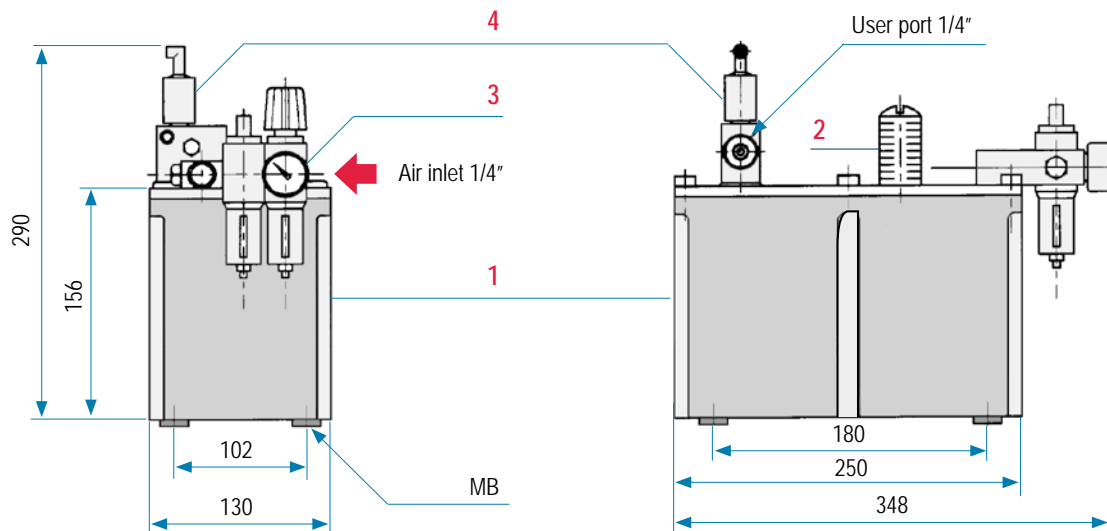

Example of Independent and Simultaneously clamping

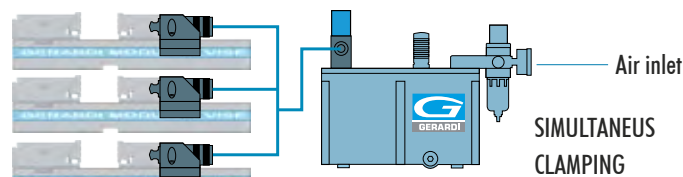
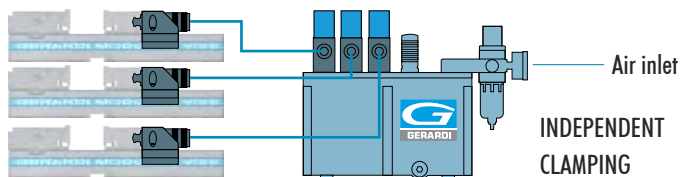
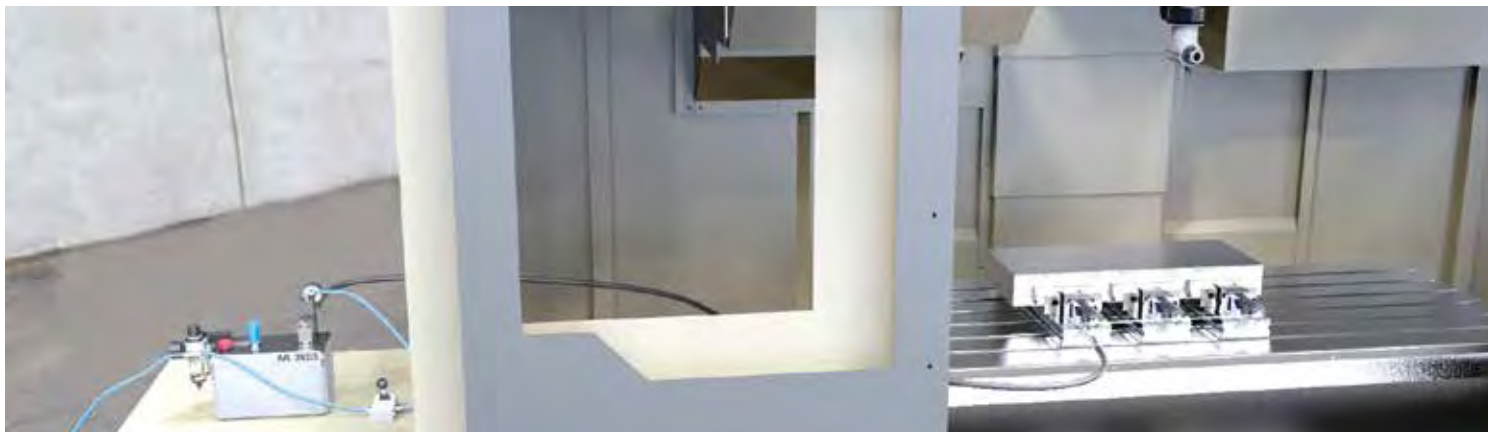

Specification

Power unit type Art.450 Type 2/3/4	
Max permissible air pressure:	7bar
Recommended air pressure:	5,5bar
Recommended grade of oil: hydraulic	68 cst
Deliveries	0,9 L / 1'
Tank capacity	3 L
Max delta on electric pilot section:	+10% - 5%
Minimum pressure on pneumatic control:	5bar
Max pressure for elettrohydraulic control:	150bar
Max number of vises / cylinders	6

The pump in it's basic version is supplied complete with:

- Teflon tank 1
- Fill plug
- Silencer 2
- Quick acting air connector fitting type D8 3
- Hydraulic control block 4

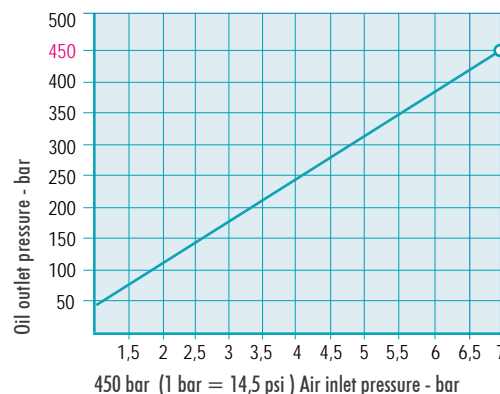

Gerardi modular elements allow perfect clamping of big workpieces which need the heaviest machining using the machine table as surface.

Modular Elements are a solution for a wide range of applications and, with the many reference points available, it is a perfect complement or alternative to single or double vises.

- No Wear - 100% HRc60 Hardened Steel
- Quick Clamping
- Modularity & Versatility
- Highest Accuracies ± 0.02 mm
- Rigidity & Safety
- Space Saving Design

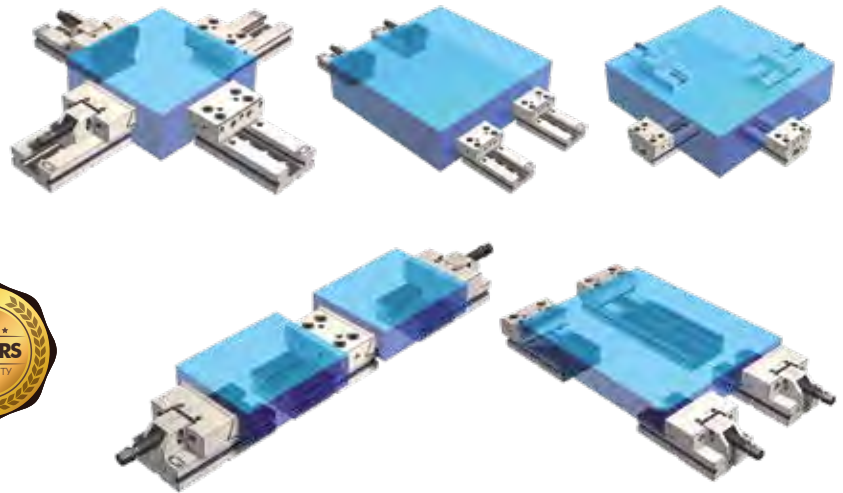

Movable Jaw Section & Base - Art.102

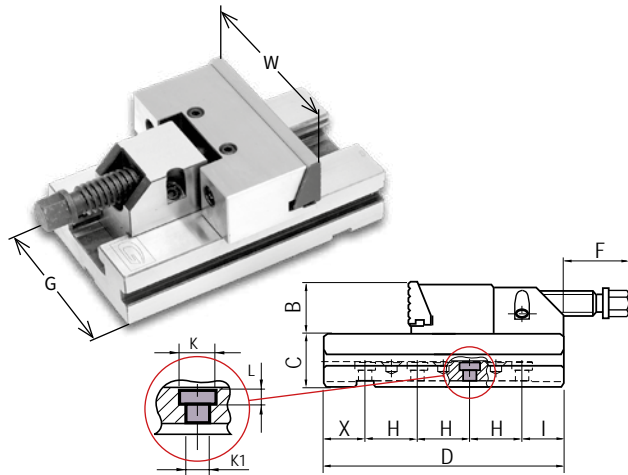

	1	2	3	4	5	6
W	100	125	150	175	200	300
B	30	40	50	60	65	80
C	35	40	50	58	70	78
D	140	160	230	240	300	350
F	55	83	82	62	92	70
G	75	95	125	145	170	195
H	40	40	50	50	100	100
I	29	39	40	82.5	50	83
L	4.5	5.5	8.5	8.5	17	17
kg	3.4	6.3	14.2	20.8	35	60
ORDER CODE	2.10.21000	2.10.22000	2.10.23000	2.10.24000	2.10.25000	2.10.26000

Fixed Jaw Section & Base - Art.103

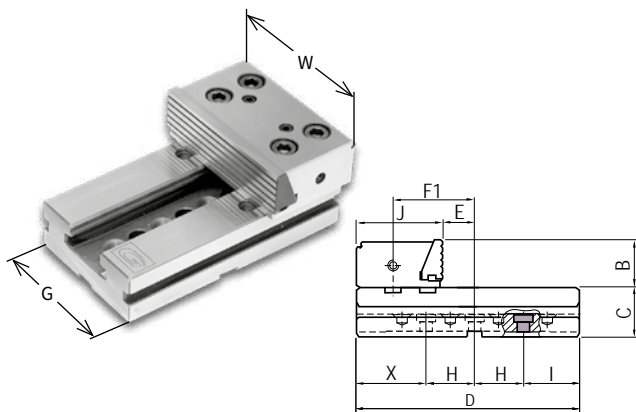

W, G, B, C & D
are as the table above
*M = Number of Holes

	1	2	3	4	5	6
J	77.9	77.9	89.4	96.9	113.4	120.4
E	33.6	33.6	33.6	33.6	33.6	33.6
F1	76	76	84.5	89	100	107
X	31	31	72.5	29	45	52
H	40	40	50	50	100	100
I	29	49	57.5	61	55	98
kg	3.3	5.8	12.6	17.8	29.8	50.5
M*	3	3	3	4	5	5
ORDER CODE	2.10.31000	2.10.32000	2.10.33000	2.10.34000	2.10.35000	2.10.36000

Double Fixed Jaw Section & Base - Art.104

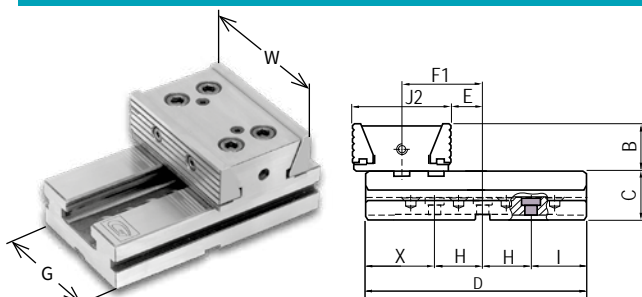

W, G, B, C, D, F1, X, H & I
are as the tables above
*M = Number of Holes

	1	2	3	4	5	6
J2	84.8	84.8	101.8	110.8	132.8	146.8
E	33.6	33.6	33.6	33.6	33.6	33.6
kg	3.4	6	13.3	18.8	30	52.5
M*	3	3	3	4	5	5
ORDER CODE	2.10.41000	2.10.42000	2.10.43000	2.10.44000	2.10.45000	2.10.46000

Grinding, Inspection & EDM - Art.666 & Art.666S

- ART.666 100% case hardened steel HRC 60 for grinding & inspection
- ART.666S X4 CR14 corrosion resistant steel for EDM
- Squareness and parallelism: 0,003 mm / 100 mm
- Supplied with 4 clamping jaws, 1 fixed work stop & 1 movable workstop

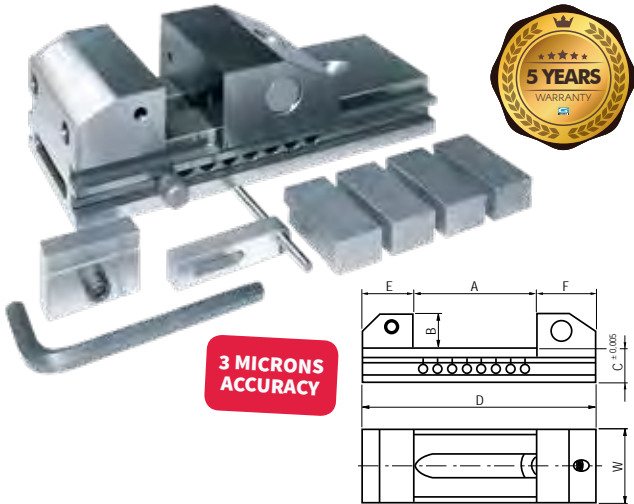

SIZE	0	1	2	3	4	5	6	7	8
kN			160 kN	160 kN	180 kN	180 kN	180 kN	180 kN	200 kN
A	27	80	100	120	160	180	200	260	200
W	30	60	75	100	125	125	125	125	160
B	15	28	40	45	50	50	50	50	63
C	15	28	35	42	50	50	50	50	63
D	75	175	220	260	330	350	370	430	410
E	15	40	50	55	65	65	65	65	80
F	33	55	50	85	105	105	105	110	130
kg	0.28	2.820	5.820	10.740	19.450	20.080	20.720	26.720	38

HRC60 STEEL FOR GRINDING & INSPECTION - ART.666

ORDER CODE	3.66.60000	3.66.61000	3.66.62000	3.66.63000	3.66.64000	3.66.65000	3.66.66000	3.66.67000	3.66.68000
------------	------------	------------	------------	------------	------------	------------	------------	------------	------------

X4 CR14 CORROSION RESISTANT STEEL FOR EDM - ART.666S

ORDER CODE	3.66.65000	3.66.65100	3.66.65200	3.66.65300	3.66.65400	3.66.65500	3.66.65600	3.66.65700	3.66.65800
------------	------------	------------	------------	------------	------------	------------	------------	------------	------------

Diagrams mechanical clamping with torque wrench

The following diagrams give the clamping force that can be obtained with each vise type (size 2 to 8) depending on the torque.

T.2 OK VISES TYPE
Torque wrench BETA 610/10X

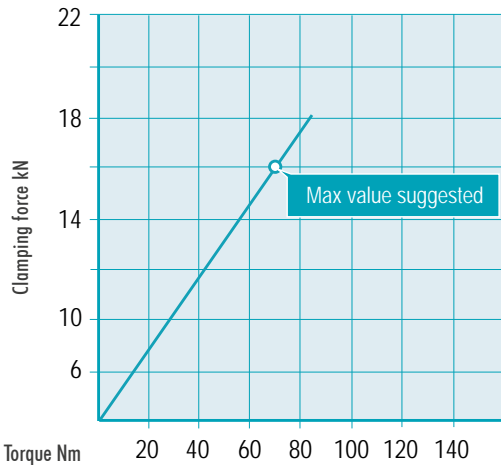

T.3 OK VISES TYPE
Torque wrench BETA 610/10X

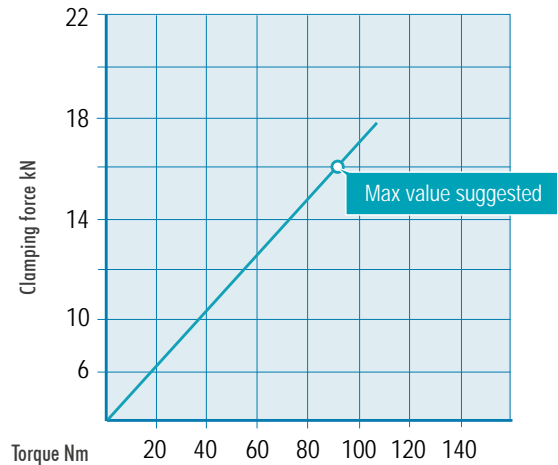

T.4-5-6-7 OK VISES TYPE
Torque wrench BETA 610/10X

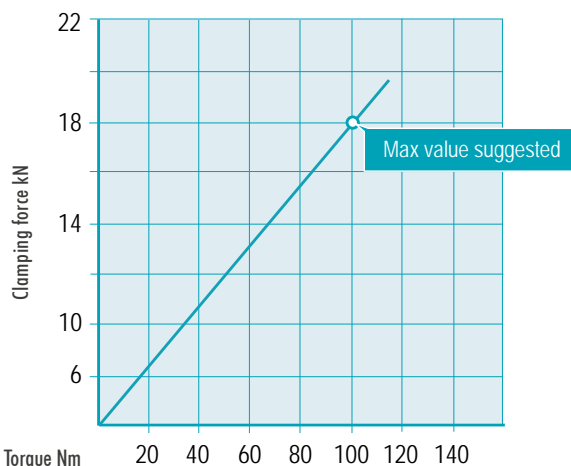

T.8 OK VISES TYPE
Torque wrench BETA 610/10X

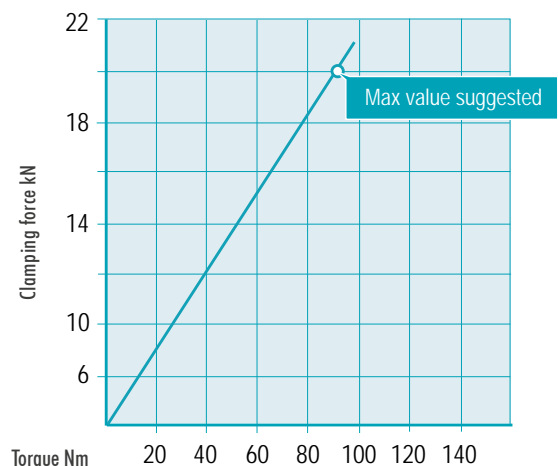

Some factor as lubrication, clamping on the machine table, frictions and more can modify above values within a $\pm 10\%$ range. For optimum operation do not exceed chart values.

Available as vise tower for vertical use or standard vise for horizontal use on VMC



▶ All parts 100% 60Hrc hardened ground & steel

▶ Fully covered clamping screw for easy maintenance

▶ All working surfaces ground within 20 microns

▶ Clamping screw contained in the base - maximise your table length with no obstruction from the screw

▶ Double thickness base for supreme rigidity

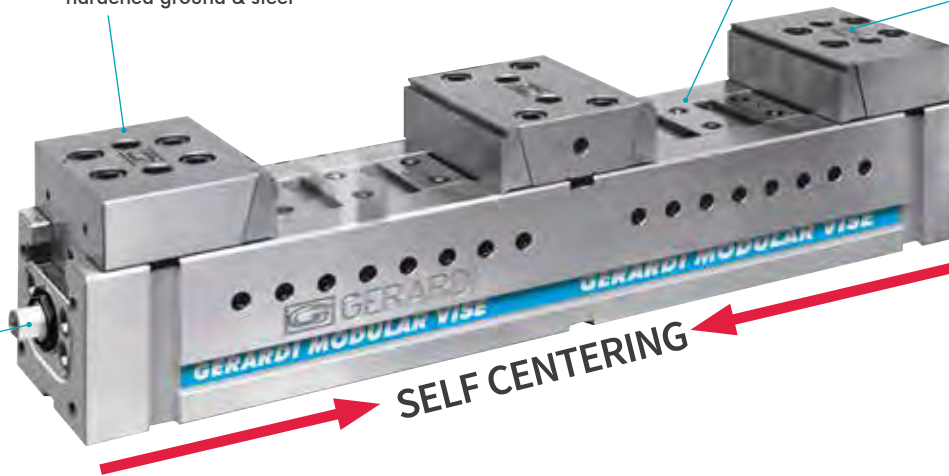

SELF CENTERING

FMS Vises: Double, Single & Self Centring

Vise Size & Clamping Force	2 25kN		3 30kN		4 30kN	5 32kN	
Base Height	90	90	90	100	100	120	140
Base Width	95	95	95	125	125	145	170
Base Length	400	500	600	500	600	600	700

Standard Configuration

Application Ideas/Extra Offers: (additional jaws may be required)

Art 860 Double with straight jaws

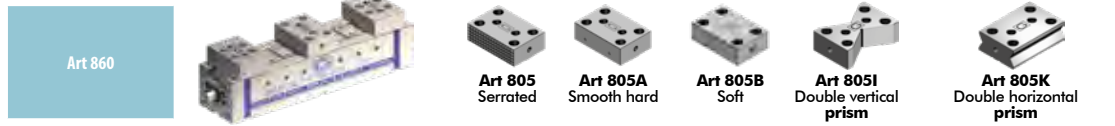

Art 863 Double with step jaws



Art 865 Quick hand change pull down jaws



Art 866 Double with floating jaws



Art 867 Double with floating jaws for plates



Art 870 Single with prismatic jaws



FMS Jaws

ART.805	Serrated	
ART.805A	Smooth Hard	
ART.805B	Soft	
ART.805i	Prismatic Vertical	
ART.805K	Prismatic Horizontal	
ART.810W	Floating	
ART.8100	Step (Small & Large)	
ART.805Q	Double Step Fixed	
ART.810T	Grip (3mm step with teeth)	

THE MOST COMPLETE

Specific for horizontal and vertical machine centres

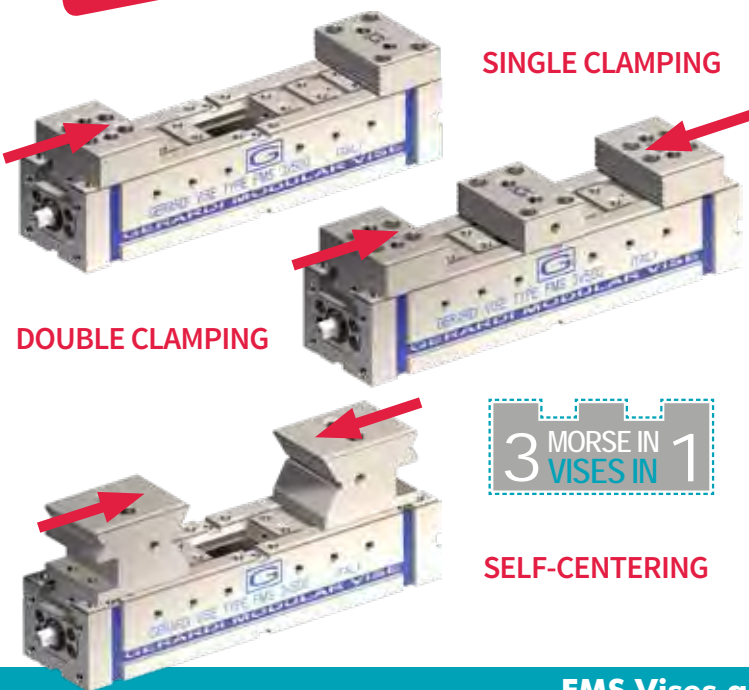

FMS Accessories

Standard Base Plate 	ART.827+828	Vertical assembly of vises or vise towers
Square Support 	ART.836	Vertical vise support
Torque Multiplier 	ART.802	Mechanical clamping with pressure multiplier
Hydraulic Motor 	ART.890	Hydraulic motors for FMS vises automation

FMS Vises and Tombstones



Vise tower made of 2 FMS vises vertical mounted with prismatic jaws for round work-pieces



FMS vise tower made of 4 vises Art.865 vertically mounted through spacers with floating movable jaws and intermediate fixed jaw.

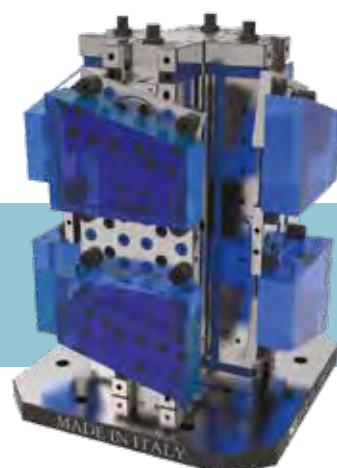

FMS vise tower made of 4 vises Art.867 vertically mounted with floating movable jaws with inserts and intermediate fixed jaw with inserts.



FMS visecube on horizontal centre



FMS integral vise cube with step movable jaws and fixed intermediate step jaw for clamping 2 workpieces each side almost as long as the vise itself.



FMS integral vise cube with prismatic movable jaws. Most compact design.

Multiflex Vise with Fixed & Movable Step Jaws - Art. 606
 Multiflex Vise with Fixed & Movable Hard Jaws - Art. 600

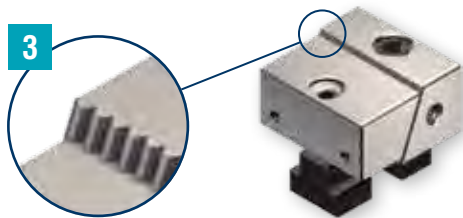
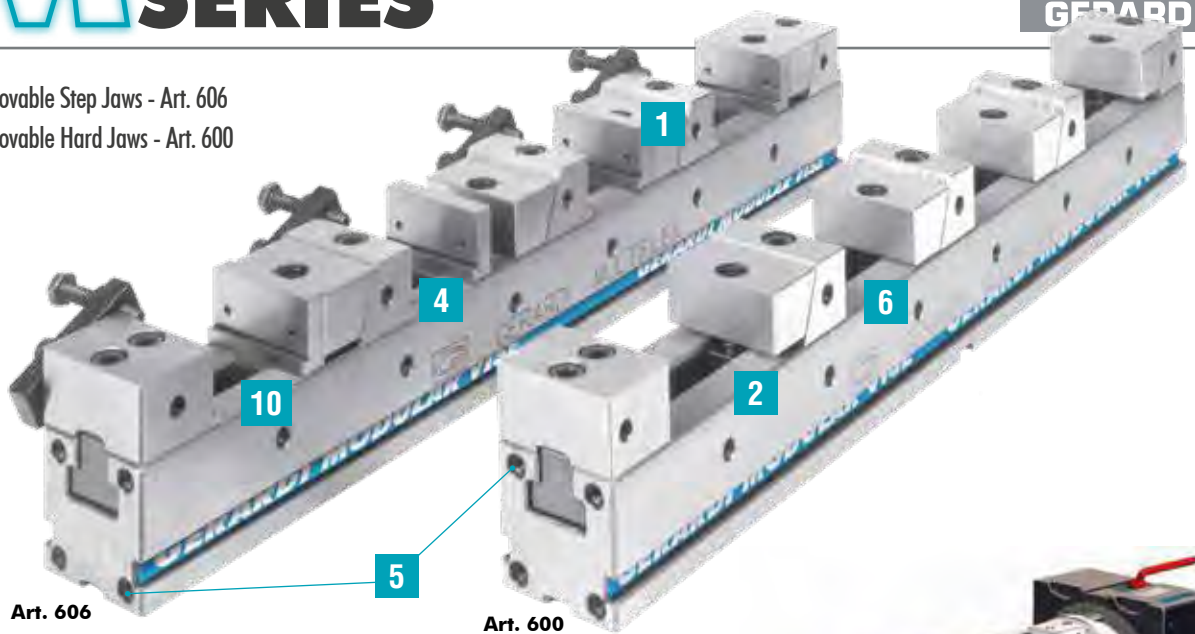

Multiflex Applications

IN LINE
7 workpieces clamped in line with 3 vises

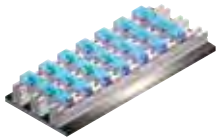

PARALLEL
28 workpieces clamped with 14 vises



PLATES
4 plates clamped in line with 3 vises

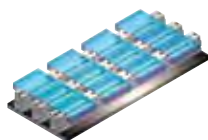

PARALLEL
14 workpieces clamped with 14 vises



MIXED PLATES
3 plates clamped in line with 4 vises

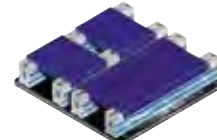

MULTIPLE
30 workpieces clamped with 5 vises



1	MODULAR & VERSATILE	Wide range of spare jaws - use for clamping 1-12 workpieces ANYTHING is possible: add or remove jaws, change of jaw position on the vise base.
2	NO WEAR	Made 100% from high quality, case hardened HRC 60 alloyed resistance steel for maximum rigidity, high performance and no wear. 5 YEARS WARRANTY on vises and all components.
3	COMB CLAMP SYSTEM WITH PULL DOWN ACTION	High clamping accuracy, power and pull down action with Gerardi COMB CLAMPING action.
4	HIGHEST ACCURACY +/-0.02mm	Every sliding and working surface is ground. Centesimal tolerances are guaranteed by checking cycles with CNC measuring machine. The perfect alignment with the machine axis is given by keyways
5	VERTICAL OR HORIZONTAL SET UP READY	MULTIFLEX vises can be vertically assembled and linked to each other or clamped to specific workholding structures like tombstones
6	HIGH & CONSISTENT CLAMPING FORCES	20-30kN clamping forces achieved with simple T wrench.
7	IDEAL FOR 4 th AXIS	Ideal for turning a vertical machining centre into a full production machine. The compact size of the tower makes it ideal for even the smallest of rotary tables
8	TAILOR MADE BASE PLATES	Tailor made to fit your machine pallet (not included in the price of tower) Art.827A+Art.828A
9	MULTIFLEX TOWERS H7 CENTRING HOLE	25mm diameter (Size 1) or 50mm diameter (Size 2&3)
10	ART.609 STEP MODULAR JAW	Can be used as a STEP JAW (supplied as standard on vise Art.606) or SMOOTH, SERRATED, PARALLEL or PRISMATIC JAW with optional jaw plates (pag.19 *).

**THE MOST
VERSATILE**

For multiple clamping from
1 to 12 workpieces of various sizes



Multiflex Vises

Multiflex Vise with Fixed & Movable jaws

Type	Jaw Height	Base Height	Length	Jaw Width	SPREAD mm	Art. 606 ORDER CODE	SPREAD mm	Art. 600 ORDER CODE
1 20kN	32/25	50	300	49	3 x 19	6.60.61300	4 x 8	6.60.01300
	32/25	50	400	49	4 x 23	6.60.61400	4 x 33	6.60.01400
	32/25	50	500	49	4 x 48	6.60.61500	4 x 58	6.60.01500
	32/25	50	600	49	4 x 73	6.60.61600	4 x 83	6.60.01600
2 30kN	32/25	50	700	49	4 x 97	6.60.61700	4 x 108	6.60.01700
	40	75	400	74	3 x 28	6.60.62400	4 x 12	6.60.02400
	40	75	500	74	4 x 24	6.60.62500	4 x 37	6.60.02500
	40	75	600	74	4 x 49	6.60.62600	4 x 62	6.60.02600
3 40kN	40	75	700	74	4 x 74	6.60.62700	4 x 87	6.60.02700
	40	75	800	74	4 x 99	6.60.62800	4 x 112	6.60.02800
	40	75	900	74	4 x 124	6.60.62900	4 x 137	6.60.02900
	60	100	700	99	4 x 44	6.60.63700	4 x 59	6.60.03700
3 40kN	60	100	800	99	4 x 69	6.60.63800	4 x 84	6.60.03800
	60	100	900	99	4 x 94	6.60.63900	4 x 109	6.60.03900
	60	100	1000	99	4 x 119	6.60.63100	4 x 134	6.60.03100

Supplied with Multiflex Vise:

4 x workstops - ART.370, 1 x T wrench - ART.376,
1 x pair of positioning keys (16mm),
6 x Table Clamps & T-Nuts

Hard smooth or serrated jaw

FOR WORKPIECES CLAMPED
DIRECTLY ON VISE BASE

Art. 600



Step jaws

FOR WORKPIECES TO
DRILL THROUGH

Art. 606



Double clamping jaws

FOR WORKPIECES ON VISE BASE
OR RISED UP WITH
PARALLELS

Art. 611

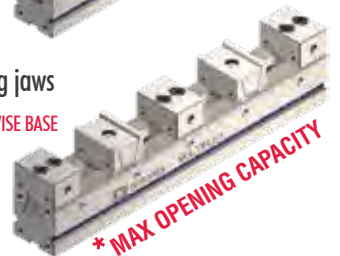

*** MAX OPENING CAPACITY**

Type	Jaw Height	Base Height	Length	Jaw Width	SPREAD*	Art. 611 ORDER CODE
1 20kN	25	50	300	49	4 x 21	6.61.11300
	25	50	400	49	4 x 46	6.61.11400
	25	50	500	49	4 x 71	6.61.11500
	25	50	600	49	4 x 94	6.61.11600
2 30kN	25	50	700	49	4 x 121	6.61.11700
	40	75	400	74	4 x 34	6.61.12400
	40	75	500	74	4 x 59	6.61.12500
	40	75	600	74	4 x 84	6.61.12600
3 40kN	40	75	700	74	4 x 109	6.61.12700
	40	75	800	74	4 x 134	6.61.12800
	40	75	900	74	4 x 159	6.61.12900
	60	100	700	99	4 x 77	6.61.13700
3 40kN	60	100	800	99	4 x 102	6.61.13800
	60	100	900	99	4 x 127	6.61.13900
	60	100	1000	99	4 x 152	6.61.13100

Multiflex Vise with double
clamping Movable jaws Art.611

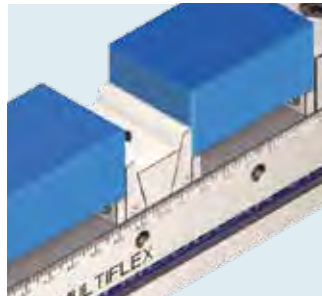

Multiflex Towers

Multiflex Tower With Fixed & Movable

Type	Jaw Height	Tower Base Section	Length/Height	Jaw Width	Spread Mm	Art. 607 ORDER CODE	Spread mm	Art. 602 ORDER CODE
1 20kN	32/25	100	300	49	3 x 19	6.60.71300	16 x 8	6.60.21300
	32/25	100	400	49	4 x 23	6.60.71400	16 x 33	6.60.21400
	32/25	100	500	49	4 x 48	6.60.71500	16 x 58	6.60.21500
	32/25	100	600	49	4 x 73	6.60.71600	16 x 83	6.60.21600
2 30kN	32/25	100	700	49	4 x 97	6.60.71700	16 x 108	6.60.21700
	40	150	400	74	3 x 28	6.60.72400	16 x 12	6.60.22400
	40	150	500	74	4 x 24	6.60.72500	16 x 37	6.60.22500
	40	150	600	74	4 x 49	6.60.72600	16 x 62	6.60.22600
3 40kN	40	150	700	74	4 x 74	6.60.72700	16 x 87	6.60.22700
	40	240	800	74	4 x 99	6.60.72800	16 x 112	6.60.22800
	60	240	700	99	4 x 39	6.60.73700	16 x 59	6.60.23700
	60	240	800	99	4 x 64	6.60.73800	16 x 84	6.60.23800
3 40kN	60	240	900	99	4 x 89	6.60.73900	16 x 109	6.60.23900
	60	240	1000	99	4 x 114	6.60.73100	16 x 134	6.60.23100

Supplied with Multiflex Tower:

16 x workstops - ART.370, 1 x T wrench - ART.376,
1 x pair of positioning keys (16mm)

Art. 602
Smooth
or
serrated
jaws

Art. 607
Step
jaws

8

10

5



Multiflex Jaws

	Vise SIZE (W)	Vise SIZE (W)		
		1 (49)	2 (74)	3 (99)
Fixed Serrated	ART.604	6.60.41000	6.60.42000	6.60.43000
Fixed Smooth	ART.604G	6.60.4G100	6.60.4G200	6.60.4G300
Fixed Grip	ART.604T	6.60.4T100	6.60.4T200	6.60.4T300
Fixed Step	ART.608	6.60.81000	6.60.82000	6.60.83000
Fixed Double Step	ART.614T	6.61.4T100	6.61.4T200	6.61.4T300

	Vise SIZE (W)	Vise SIZE (W)		
		1 (49)	2 (74)	3 (99)
Movable Smooth	ART.605	6.60.51000	6.60.52000	6.60.53000
Movable Serrated	ART.605S	6.60.5S100	6.60.5S200	6.60.5S300
Movable Step	ART.609	6.60.91000	6.60.92000	6.60.93000
Movable Grip	ART.609T	6.60.9T100	6.60.9T200	6.60.9T300

*Optional Jaw Plates for
Modular Step Jaw - Art.609

	Vise SIZE (W)	Vise SIZE (W)		
		1 (49)	2 (74)	3 (99)
Soft	ART.610B	6.61.0B100	6.61.0B200	6.61.0B300
Smooth	ART.610C	6.61.0C100	6.61.0C200	6.61.0C300
Serrated	ART.610D	6.61.0D100	6.61.0D200	6.61.0D300
Parallel	ART.610E	6.61.0E100	6.61.0E200	6.61.0E300
Prismatic	ART.610F	6.61.0F100	6.61.0F200	6.61.0F300

Clamp on Just 3mm for Full 5 Sided Machining



1	3-5mm STEP JAW	Supplied with 5mm step jaw as standard for full 5 sided machining. 3mm GRIP jaw also available.
2	NO WEAR	Made 100% from high quality, case hardened HRC 60 alloyed resistance steel in order to give maximum rigidity, high performance and no wear. 5 YEARS WARRANTY on all the vises and components.
3	SELF CENTRING OR ECCENTRIC ADJUSTMENT	Self centering with possibility of clamping outside to inside and vice versa. Eccentric jaw adjustments of 2mm.
4	GROUND SURFACES HIGHEST ACCURACY +/-0,02mm	Every sliding and working surface is ground. Centesimal tolerances are guaranteed by checking cycles with CNC measuring machine. The perfect alignment with the machine axis is given by keyways
5	DIRECT VISE SET-UP	Supplied with ground positioning keys Art.297 for clamping through keyways and positioning pin Art.640P for 5th axis machines.
6	MONO-BLOCK RISERS	Different Heights risers machined from 1 solid piece of aluminum
7	TAPPED & REAMED HOLES	Up to 26 (depending on size of space) reamed and tapped holes for positioning vise/spacer to table or 5th axis.
8	REVERSIBLE DOUBLE STEP JAW	Size 3 Multitasking vise supplied with reversible step jaw. 5mm step on both sides, large step on inside.
9	ZERO POINT READY	Reduce set-up times by 95%. Immediate positioning within 5 microns, pneumatic clamping of the vise to the Zero Point via pull calibrated stud.

Supplied with Every Multitasking Vise:

- 1 x workstop ART.370,
- 1 x pair of positioning keys (16mm) Art 297 (Type1 & Type2)
- 1 x positioning pin Art.640P,
- 1 x "T" wrench ART.376 (Type3)



Multitasking Vises

Art. 640 Size 1&2

Art. 640 Size 3 -166

Art. 640 Size 3 -266



8

Multitasking Risers

Art. 641H

Art. 641H

Art. 641H

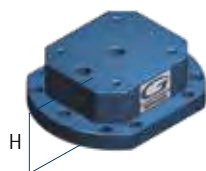

Supplied with 1 straight pin **Art. 79** & 1 positioning pin **Art. 640P**

Multitasking Jaws

Art. 645B
Soft



Art. 645F
Prismatic



Art. 645T (suggested)
Grip (3mm step)

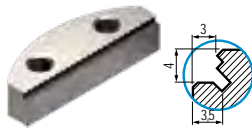

Art. 645D
Serrated



Art. 645C
Hard Smooth



Art. 655J
Prismatic Large



Pneumatic Zero Point Module

- Quickest set up, practically immediate
- Pre-set workpieces offline
- Greatest reduction in scrap (if re-work is needed you can put back on the machine in same place within 5 microns)
- Typically Zero Point used in 3 machining centres creates as much capacity as 1 new VMC (for about 15% of the cost)

QUICKEST RETURN ON INVESTMENT!
Payback 1 Month



Multitasking Vises & Accessories

Vise Size	1	2	3	
Jaw Width	74	99	138	138
Max Opening	65	95	108	208
Jaw Height	15	20	30	30
Total Height	85	115	113	113
Base Size	ø120	ø160	145 x 166	145 x 266

Multitasking Vises

ORDER CODE	6.64.01000	6.64.02000	7.64.03166	7.64.03266
------------	------------	------------	------------	------------

Multitasking Riser

ORDER CODE	Multitasking Riser			
H= 100mm	7.64.1H100/100	7.64.1H200/100	7.64.1H3166/100	7.64.1H3266/100
H= 75mm	7.64.1H100/75	7.64.1H200/75	7.64.1H3166/75	7.64.1H3266/75
H= 50mm	7.64.1H100/50	7.64.1H200/50	7.64.1H3166/50	7.64.1H3266/50

Multitasking Jaws

ORDER CODE	Multitasking Jaws			
ART645B SOFT JAW	6.64.5B100	6.64.5B200	7.64.5B300	
ART645C HARD JAW	6.64.5C100	6.64.5C200	7.64.5C300	
ART645D SERRATED JAW	6.64.5D100	6.64.5D200	7.64.5D300	
ART645F PRISMATIC JAW	6.64.5F100	6.64.5F200	7.64.5F300	
ART645T GRIP JAW	6.64.5T100	6.64.5T200	7.64.5T300	
ART655J PRISMATIC JAW	ø 30 ÷ 45 7.65.5J100	ø 45 ÷ 70 7.65.5J200	ø 44 ÷ 68 7.65.5J316	ø 48 ÷ 102 7.65.5J326

Zero Point Module (Spacer, Zero Point unit, Pull Stud, Pin, Screw)

ORDER CODE	9.63.20000	9.64.20000
------------	------------	------------

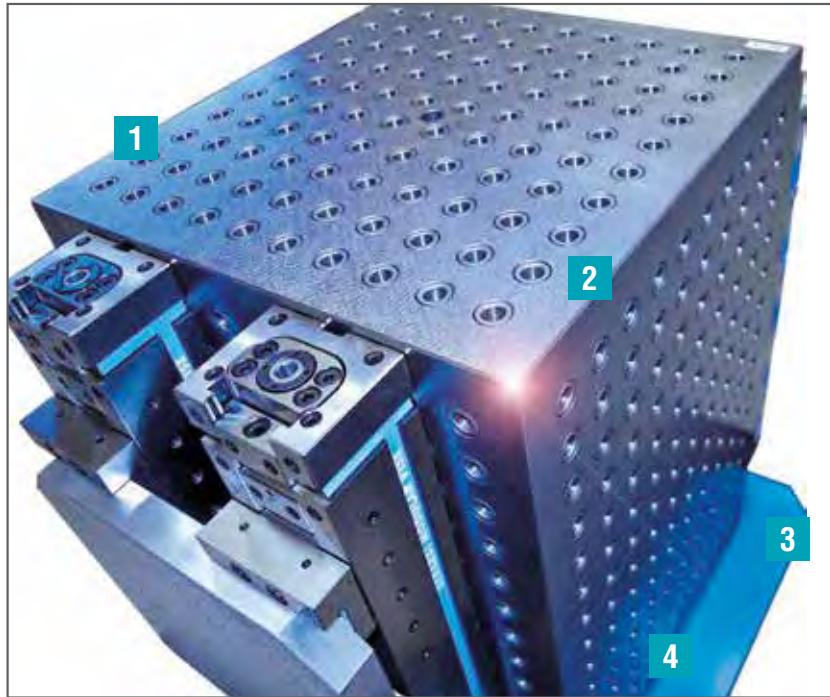

- | | |
|---|--|
| 1 | Cast Iron G30 CASTING - no fabrication!
MORE RIGID - HIGHER PRECISION |
| 2 | Double stress relieving heat treatment |
| 3 | Hand scraping of bottom of base for perfect planarity |
| 4 | Base face tailor made ready to fit onto the specific machine tool pallet |

Available in 4 Finishings

- | | |
|---|--|
| A | TYPE A - rough milled with 43-45mm wall thickness.
Light cubes wall thickness only between 20-35mm |
| B | TYPE B - rough milled with 43-45mm wall thickness.
Base with 4x Ø20mmF7 holes & M16 bottom threads |
| C | TYPE C - Completely machined all over +0.02mm.
Base with 4x Ø20mmF7 holes & M16 bottom threads |
| D | TYPE E - As per type C, but with calibrated M16 threads.
Base with 4x Ø20mmF7 holes & M16 bottom threads |

A Rough Milled

General tolerance ± 2 mm

Cube, Art.53A

Light cubes

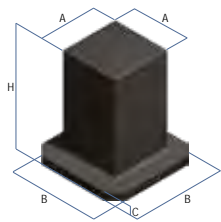

A	B	C	H	kg	CODE
210	410	50	760	178	8.53.A10055
260	410	50	860	240	8.53.A10085
280	410	50	520	210	8.53.A00110
260	510	50	760	249	8.53.A10105
360	510	50	710	372	8.53.A00171
360	640	50	960	488	8.53.A10185
460	640	50	560	431	8.53.A00190
460	640	50	660	486	8.53.A00200
460	640	50	960	655	8.53.A10205

2 Sided Tombstone, Art.55A

Light cubes

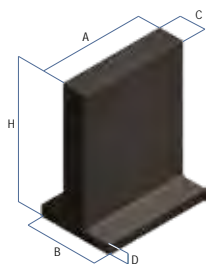

A	B	C	D	H	kg	CODE
410	410	160	60	510	215	8.55.A00051
410	410	160	55	670	262	8.55.A00052
410	410	160	60	860	250	8.55.A10050
510	510	160	55	710	350	8.55.A00053
510	510	210	60	610	340	8.55.A00054
510	510	210	60	910	416	8.55.A10085
560	460	160	60	830	430	8.55.A00160
640	460	160	60	830	486	8.55.A00170
640	460	260	70	910	589	8.55.A00171
640	640	210	60	870	579	8.55.A00172
640	640	210	60	960	574	8.55.A10172
640	640	260	60	710	521	8.55.A00173
360	460	160	70	660	250	8.55.A00180
810	460	160	70	860	632	8.55.A00190

Cross Cube, Art.57A

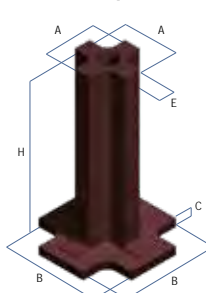

A	B	C	E	H	kg	CODE
210	510	45	80	760	172	8.57.A00100
210	510	45	80	660	156	8.57.A00105
260	510	45	80	760	212	8.57.A00106
280	510	45	80	860	254	8.57.A00110
240	510	45	110	860	237	8.57.A00120
310	510	45	150	860	291	8.57.A00130
310	640	45	150	960	357	8.57.A00140
380	510	45	200	960	419	8.57.A00145
410	510	55	100	860	254	8.57.A00150

More sizes and bespoke designs on request.

B Rough Milled, Base Prepared

General tolerance ± 2 mm

Cube, Art. 53B

Light cubes

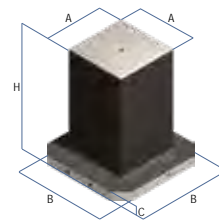

A	B	C	H	kg	CODE
210	400	45	750	167	8.53.B10055
260	400	45	850	229	8.53.B10085
280	400	45	510	198	8.53.B00110
260	500	45	750	234	8.53.B00105
360	500	45	700	356	8.53.B00171
360	630	45	950	634	8.53.B10185
460	630	45	550	409	8.53.B00190
460	630	45	650	463	8.53.B00200
460	630	45	950	634	8.53.B10205

2 Sided Tombstone, Art.55B

Light cubes

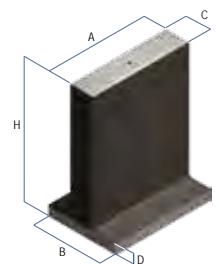

A	B	C	D	H	kg	CODE
400	400	160	55	500	199	8.55.B00051
400	400	160	50	660	244	8.55.B00052
400	400	160	55	850	239	8.55.B10050
500	500	160	50	700	331	8.55.B00053
500	500	210	55	600	316	8.55.B00054
500	500	210	55	900	402	8.55.B10085
550	450	160	55	820	406	8.55.B00160
630	450	160	55	820	460	8.55.B00170
630	450	260	65	900	564	8.55.B00171
630	630	210	55	860	545	8.55.B00172
630	630	210	55	950	553	8.55.B10172
630	630	260	55	700	485	8.55.B00173
350	450	160	65	650	232	8.55.B00180
800	450	160	65	850	604	8.55.B00190

Cross Cube, Art.57B

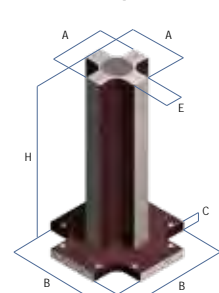

A	B	C	E	H	kg	CODE
203	500	40	80	750	157	8.57.B00100
203	500	40	80	650	142	8.57.B00105
253	500	40	80	750	197	8.57.B00106
273	500	40	80	850	242	8.57.B00110
233	500	40	110	850	218	8.57.B00120
303	500	40	150	850	269	8.57.B00130
303	630	40	150	950	327	8.57.B00140
373	500	40	200	950	400	8.57.B00145
403	500	50	100	850	241	8.57.B00150

More sizes and bespoke designs on request.

Today also available with lighter weights

Complete Pallets for Your Machining Centre



Please state machine and model number when ordering.

	MACHINE PALLET SIZE			
	400mm	500mm	630mm	800mm
GRID PALLET - ART. 85				
ORDER CODE	8.85.4040...	8.85.5050...	8.85.6363...	8.85.8080...
PALLET WITH H7 T-SLOT - ART. 86				
ORDER CODE	8.86.4040...	8.86.5050...	8.86.6363...	8.86.8080...

Steel Base Plates

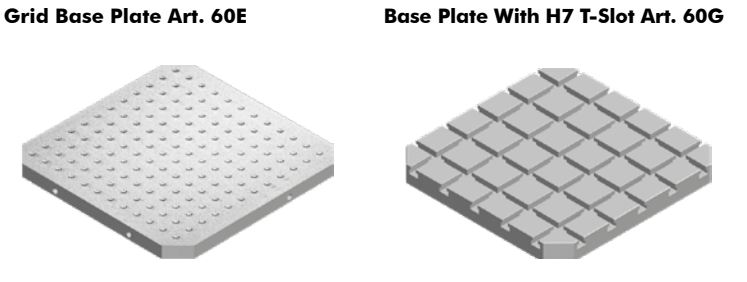

ART.60E Please specify grid pitch. **ART.60G** Please specify T-Slot size

	MACHINE PALLET SIZE			
	400mm	500mm	630mm	800mm
GRID BASE PLATE - ART. 60E				
ORDER CODE	8.60.E400400A	8.60.E500500A	8.60.E630630A	8.60.E800800A
BASE PLATE WITH H7 T-SLOT - ART. 60G				
ORDER CODE	8.60.G400400A	8.60.G500500A	8.60.G630630A	8.60.G800800A

C Completely Machined

Cube, Art. 53C

Light cubes

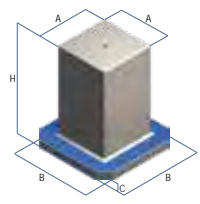

Vise mounting alternatives on completely machined tombstones

General tolerance ± 0.02 mm

A	B	C	H	kg	CODE
200	400	40	750	142	8.53.C10055
250	400	40	850	196	8.53.C10085
270	400	40	510	176	8.53.C00110
250	500	40	750	201	8.53.C10105
350	500	40	700	317	8.53.C00171
350	630	40	950	411	8.53.C10185
450	630	40	550	367	8.53.C00190
450	630	40	650	415	8.53.C00200
450	630	40	950	568	8.53.C10205

2 Sided Tombstone, Art.55C

Light cubes

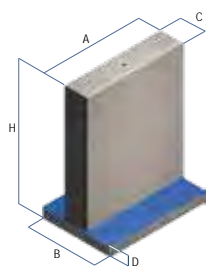

A	B	C	D	H	kg	CODE
400	400	150	50	500	193	8.55.C00051
400	400	150	45	660	222	8.55.C00052
400	400	150	50	850	203	8.55.C10050
500	500	150	45	700	290	8.55.C00053
500	500	200	50	600	287	8.55.C00054
500	500	200	50	900	353	8.55.C10085
550	450	150	50	820	369	8.55.C00160
630	450	150	50	820	418	8.55.C00170
630	450	250	60	900	513	8.55.C00171
630	630	200	50	850	504	8.55.C00172
630	630	200	50	950	489	8.55.C10172
630	630	250	50	700	447	8.55.C00173
350	450	150	60	650	213	8.55.C00180
800	450	150	60	850	548	8.55.C00190

Cross Cube, Art.57C

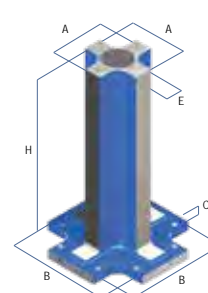

A	B	C	E	H	kg	CODE
200	500	40	80	750	154	8.57.C00100
200	500	40	80	650	140	8.57.C00105
250	500	40	80	750	194	8.57.C00106
270	500	40	80	850	240	8.57.C00110
230	500	40	110	850	214	8.57.C00120
300	500	40	150	850	264	8.57.C00130
300	630	40	150	950	322	8.57.C00140
370	500	40	200	950	397	8.57.C00145
400	500	50	100	850	239	8.57.C00150

More sizes and bespoke designs on request.

D Grid (50mm pitch)

Cube, Art. 53E

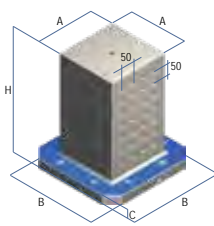

General tolerance ± 0.02 mm

A	B	C	H	kg	ORDER CODE
250	400	40	660	201	8.53.E00081
250	400	40	550	174	8.53.E00080
270	400	40	510	176	8.53.E00110
250	500	40	750	249	8.53.E00105
350	500	40	700	317	8.53.E00171
450	630	40	550	367	8.53.E00190
450	630	40	650	415	8.53.E00200
500	630	40	860	565	8.53.E00211

2 Sided Tombstone, Art.55E

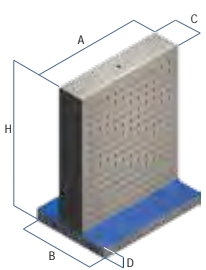

A	B	C	D	H	kg	ORDER CODE
400	400	150	50	500	193	8.55.E00051
400	400	150	45	660	222	8.55.E00052
500	500	150	45	700	290	8.55.E00053
500	500	200	50	600	287	8.55.E00054
550	450	150	50	820	369	8.55.E00160
630	450	150	50	820	418	8.55.E00170
630	450	250	60	900	513	8.55.E00171
630	630	200	50	850	504	8.55.E00172
630	630	250	50	700	447	8.55.E00173
350	450	150	60	650	213	8.55.E00180
800	450	150	60	850	548	8.55.E00190

Cross Cube, Art.57E

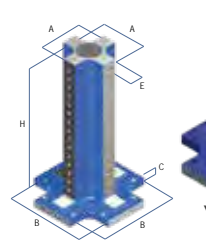

A	B	C	E	H	kg	ORDER CODE
200	500	40	80	750	154	8.57.E40100
200	500	40	80	650	140	8.57.E40105
250	500	40	80	750	194	8.57.E40106
270	500	40	80	850	240	8.57.E40110
230	500	40	110	850	214	8.57.E40120
300	500	40	150	850	264	8.57.E40130
300	630	40	150	950	322	8.57.E40140
370	500	40	200	950	397	8.57.E40145
400	500	50	100	850	239	8.57.E40150

Vise mounting on completely machined and interfaced tombstones

More sizes and bespoke designs on request.

Zero Point

FREE!
1 Pull-stud &
1 teflon cup with
O-Ring Art.9
**WITH EVERY
ZERO POINT
MODULE**

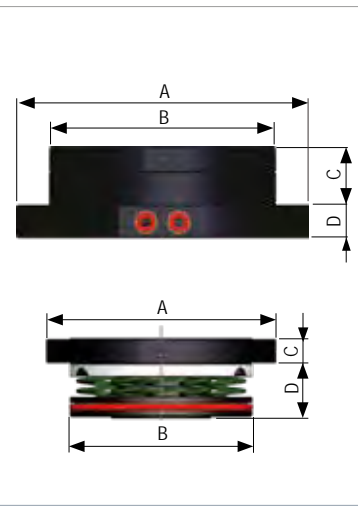

ZERO POINT type (size)	
	kN
ART.	
A	
B	
C	
D	
SHAPE	
Kg	
ORDER CODE	

DOUBLE ZERO-POINT ART.665T **NEW!**

Zero Point head plates with Built In Mounted Zero Point Modules Art. 665

TYPE 1

Material	Kg	ORDER CODE
Steel	5,2	9.66.5T100

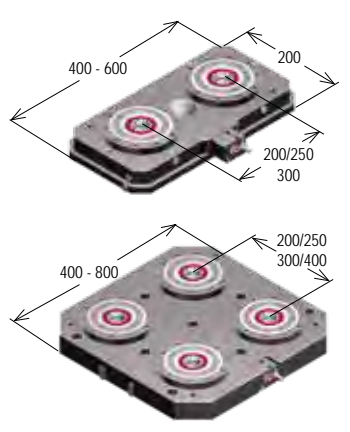

Art. 81P with Art. 665 x 2	BASE PLATE		
	200x400	200x500	200x600
ORDER CODE	9.81.P204052	9.81.P205052	9.81.P206052

TYPE 2

Material	Kg	ORDER CODE
Steel	9,7	9.66.5T200

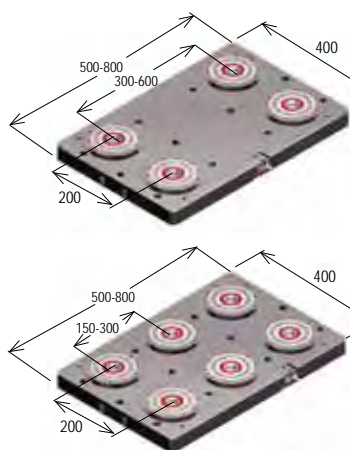

Art. 80P with Art. 665 x 4	BASE PLATE			
	400x400	500x500	630x630	800x800
ORDER CODE	9.80.P404054	9.80.P505054	9.80.P636354	9.80.P808054

Art. 81P with Art. 665 x 4	BASE PLATE			
	400x500	400x600	400x700	400x800
ORDER CODE	9.81.P405054	9.81.P406054	9.81.P407054	9.81.P408054

TYPE 3

Material	Kg	ORDER CODE
Steel	18,8	9.66.5T300

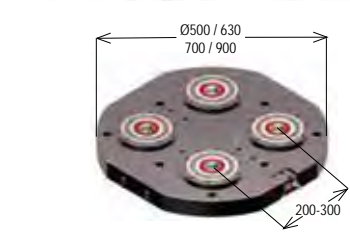

Art. 81P with Art. 665 x 6	BASE PLATE			
	400 x 500	400 x 600	400 x 700	400 x 800
ORDER CODE	9.81.P405056	9.81.P406056	9.81.P407056	9.81.P408056

Art. 82P with Art. 665 x 4*	BASE PLATE			
	Ø 500	Ø 630	Ø 700	Ø 900*
ORDER CODE	9.82.P504054	9.82.P635054	9.82.P705054	9.82.P906356

*9.82P906356 has 6 Zero Point Modules Art. 665

**IMMEDIATE
POSITIONING &
CLAMPING**

Set Up Times Reduced by 90%
Repositioning Accuracy Within 0.005 mm



Opening Pressure BAR 7 ÷ 14



FLANGE MOUNTING

1	2	2	3
up to 14Kn	up to 18Kn	up to 25Kn	up to 40Kn
664 (MULTIPLE) 664S (SINGLE with 4-Keyways)	664 (MULTIPLE)	664S (SINGLE with 4-Keyways)	664 (MULTIPLE) 664S (SINGLE with 4-Keyways)
Ø138	Ø178	Ø188	Ø213
90	Ø138h7	120	Ø168h7
30	35	45	45
20	20	20	25
2,7	6	6,5	11
9.66.41000 9.66.45100	9.66.42000	9.66.45200	9.66.43000 9.66.45300



BUILT-IN MOUNTING

1	2	2	3
up to 14Kn	up to 18Kn	up to 25Kn	up to 40Kn
665 (MULTIPLE) 665S (SINGLE with 4-Keyways)	665 (MULTIPLE)	665S (SINGLE with 4-Keyways)	665 (MULTIPLE) 665S (SINGLE with 4-Keyways)
90	Ø138	120	Ø168
Ø84	Ø110h7	Ø110h7	Ø138h7
12	15	15	15
30	33	42	47
1,5	2,5	2,5	5,8,2
9.66.51000 9.66.55100	9.66.52000	9.66.55200	9.66.53000 9.66.55300

Quickest Return On Your Investment

- Quickest set up, practically immediate
- Pre-set workpieces offline
- Greatest reduction in scraps (if re-work is need you can put back on the machine in same place)
- Typically Zero Point used in 3 machining centres creates as much capacity as 1 new VMC (for about 15% of the cost)

**PAYBACK IN
1 MONTH***

Zero Point
Interface Plate
200 x 400
Art. 81P

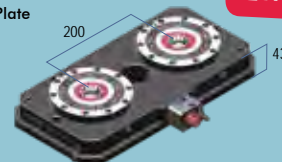

ORDER CODE

9.81.P204052

*Calculation based on 2 hours daily set up time saving at £35 per hour for 50 working weeks.

This also gives a potential extra profit of £15,400 per annum

Zero Point Accessories

**Kit for Single
Operation**
Excludes Zero Point
Module
Art. 409

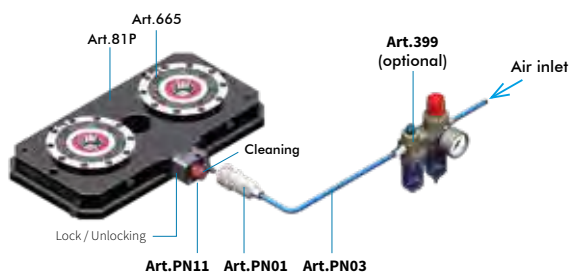

**Kit for Double
Operation**
Excludes Zero Point
Module
Art. 409B

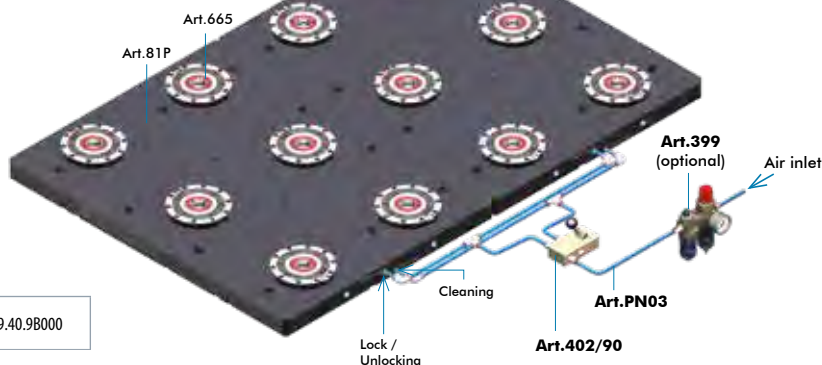

ORDER CODE 9.40.98000

Zero Point Applications

Riser interfaced with vise assembled

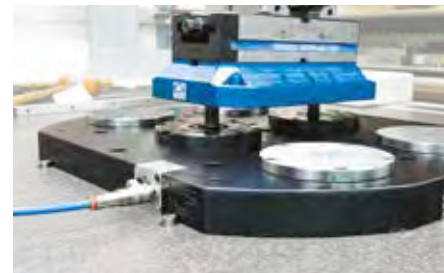

Plate interfaced with vise assembled



Double Zero Point



Female Pull Studs

Easy access and remove also from clamped fixtures

Centring Pull Stud
Female thread
Art. 10A



Clamping Pull Stud
Female thread
Art. 10B



Male Pull Studs

Easy preparation and set-up of workpiece or fixture for Zero Point

Centring Pull Stud
Male thread
Art. 11A



Clamping Pull Stud
Male thread
Art. 11B



Type "A" is used for both centering and clamping, while type "B" is only for clamping.

OFFSET SERIES

AUTOMATIC TOOL CHANGE

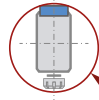

∅min*

*Min bore for internal machining. Excluding cutting tool



Model	Coolant (options)	TYPE	Rotation	Output	L	∅ min*	Rpm	Nm	ORDER CODE
GR90-5	Water	1	↻	P6 SCHAUBLIN 00.3/5	132	38	8.000	9	9.GR9.05000
GR90-10	Water	1	↻	ER16 01/10	122	66	4.000	20	9.GR9.10000
GR90-16	Water	1	↻	ER25 01/16	132	82	4.000	20	9.GR9.16000
GL90-S40	Water	4	↻	ISO/CAT/BT 40	160	148	4.000	140	9.GR9.S4000

Offset series for machining in narrow spaces with coolant input directly from machine spindle and output through the tool at 70BAR

DOUBLE OUTPUT

AUTOMATIC TOOL CHANGE

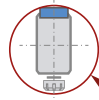

∅min*

*Min bore for internal machining. Excluding cutting tool



Model	TYPE	Rotation	Output	L	∅ min*	Rpm	Nm	ORDER CODE
G90-16-2U	1	↻↻	ER25 01/16	75	167	4.000	24	9.G90.162U0
G90-16L 2U	1	↻↻	ER25 01/16	152	167	4.000	24	9.G90.16L2U0
G90-20 2U	2	↻↻	ER32 02/20	92	212	4.000	40	9.G90.202U0
G90-20L 2U	2	↻↻	ER32 02/20	172	212	4.000	40	9.G90.20L2U0
G90-30 2U	3	↻↻	ER40 03/30	107	246	4.000	75	9.G90.302U0
G90-30L 2U	3	↻↻	ER40 03/30	177	246	4.000	75	9.G90.30L2U0

With the double option output you can optimize the production cycle avoiding extra set-up

XL SERIES

MANUAL TOOL CHANGE



Model	Coolant (options)	TYPE	Rotation	Output	L	∅ min*	Rpm	Nm	ORDER CODE
-------	-------------------	------	----------	--------	---	--------	-----	----	------------

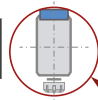

∅min*

*Min bore for internal machining. Excluding cutting tool

G90-S40	Water	4	↻	ISO/CAT/BT 40	110	192	4.000	140	9.G90.S4001
G90-S40 XL	Water	5	↻	ISO/CAT/BT 40	250	205	4.000	140	9.G90.S40XL1
G90-S40 XL xx	Water	5	↻	ISO/CAT/BT 40	400 500 600 700	202	4.000	140	9.G90.S40XL .400 - .500 - .600 - .700
G90-S50	Water	6	↻	ISO/CAT/BT 50	300	305	3.000	400	9.G90.S5001
G90-S50 XL xx	Water	6	↻	ISO/CAT/BT 50	400 500 600 700 800	297	3.000	400	9.G90.S50XL .400 - .500 - .600 - .700 - .800



Angle heads Classic Line XL MTC series, are ideal for large machine tools and milling machines. These angle heads are designed for heavy duty cutting (turbines, valves, big castings, etc.).

**INTEGRAL
SHANK & SHAFT**



CLASSIC LINE
Integral System Angle Heads



ATC Series (Automatic Tool Change)

series
LIGHT

Ideal for milling, drilling
and tapping at $\pm 90^\circ$



GL90-7 / GL90-10 / GL90-16 / GTU-10							
Model	Coolant (options)	TYPE	Rotation	Output	Nm	Rpm	ORDER CODE
GL90-7		0		ER 11 - 01/7	5	10.000	9.GL9.07000
GL90-10		0		ER 16 - 01/10	10	10.000	9.GL9.10000
GL90-16		1		ER 25 - 01/16	24	8.000	9.GL9.16000
GTU-10	-	0		ER 16 - 01/10	10	6.000	9.GTU.10000

series
STD 90°

SMALL angle heads
Ideal for milling, drilling
and tapping at $\pm 90^\circ$



G90-5 / G90-7 / G90-10 / G90-16							
Model	Coolant (options)	TYPE	Rotation	Output	Nm	Rpm	ORDER CODE
G90-5	-	1		ER 8 - 00,5/5	4	10.000	9.G90.05000
*G90-7		1		ER 11 - 01/7	5	10.000	9.G90.07000
*G90-10		1		ER 16 - 01/10	10	10.000	9.G90.10000
*G90-16		1		ER 25 - 01/16	24	8.000	9.G90.16000

*ALSO AVAILABLE "L" SERIES WITH THE LONGER BODY

series
STD 90°

MEDIUM & BIG angle heads
Ideal for milling, drilling
and tapping at $\pm 90^\circ$



G90-20 / G90-30 / G90-S40							
Model	Coolant (options)	TYPE	Rotation	Output	Nm	Rpm	ORDER CODE
*G90-20		2		ER 32 - 02/20	40	4.000	9.G90.20000
*G90-30		3		ER 40 - 03/30	75	4.000	9.G90.30000
*G90-S40		4		ISO40/ CAT/BT40	140	4.000	9.G90.S40000

*ALSO AVAILABLE "L" SERIES WITH THE LONGER BODY

series
GMU

Angle heads with ADJUSTABLE
angle from 0° to 90°



GMU-13 / GMU-16 / GMU-20							
Model	Coolant (options)	TYPE	Rotation	Output	Nm	Rpm	ORDER CODE
*GMU-13	-	0		ER 20 - 01/13	6	4.000	9.GMU.13000
GMU-16	-	1		ER 25 - 01/16	18	4.000	9.GMU.16000
GMU-20	-	2		ER 32 - 02/20	32	4.000	9.GMU.20000

*ALSO AVAILABLE "L" SERIES WITH THE LONGER BODY

MTC Series (Manual Tool Change)

series
STD 90°

Ideal for milling, drilling
and tapping at $\pm 90^\circ$



G90-5 MTC / G90-7 MTC							
Model	Coolant (options)	TYPE	Rotation	Output	Nm	Rpm	ORDER CODE
G90-5	-	1		ER 8 - 00,5/5	4	10.000	9.G90.05001
*G90-7		1		ER 11 - 01/7	5	10.000	9.G90.07001

G90-10 MTC / G90-16 MTC							
Model	Coolant (options)	TYPE	Rotation	Output	Nm	Rpm	ORDER CODE
*G90-10		1		ER 16 - 01/10	10	10.000	9.G90.10001
*G90-16		1		ER 25 - 01/16	24	8.000	9.G90.16001

G90-20 MTC / G90-30 MTC							
Model	Coolant (options)	TYPE	Rotation	Output	Nm	Rpm	ORDER CODE
*G90-20		2		ER 32 - 02/20	40	4.000	9.G90.20001
*G90-30		3		ER 40 - 03/30	75	4.000	9.G90.30001

*ALSO AVAILABLE "L" SERIES WITH THE LONGER BODY

series
DOUB2E

Angle heads series with
2 opposite outputs



G90-16 2U MTC / G90-20 2U MTC / G90-30 2U MTC							
Model	Coolant (options)	TYPE	Rotation	Output	Nm	Rpm	ORDER CODE
*G90-16 2U	-	1		ER 25 - 01/16	24	4.000	9.G90.162U01
*G90-20 2U	-	2		ER 32 - 02/20	40	4.000	9.G90.202U01
*G90-30 2U	-	3		ER 40 - 03/30	75	4.000	9.G90.302U01

*ALSO AVAILABLE "L" SERIES WITH THE LONGER BODY

series
GMU

Angle heads with adjustable
angle from 0° to 90°



GMU-16 MTC / GMU-20 MTC / GMU-S40 / GMU-S50 MTC							
Model	Coolant (options)	TYPE	Rotation	Output	Nm	Rpm	ORDER CODE
GMU-16		1		ER 25 - 01/16	18	4.000	9.GMU.16001
GMU-20		2		ER 32 - 02/20	32	4.000	9.GMU.20001
GMU-S40 125		6		ISO40/ CAT/BT40	100	3.000	9.GMU.S4001.125
GMU-S40		5		ISO40/ CAT/BT40	100	3.000	9.GMU.S4001
GMU-S50		6		ISO40/ CAT/BT50	220	3.000	9.GMU.S5001

INTERNAL COOLANT FEED THROUGH THE TOOL OPTIONS:
- 10BAR THROUGH ROTATING DISTRIBUTOR
- FROM 30 TO 70BAR THROUGH MACHINE SPINDLE

DIRECTION OF ROTATION OPPOSITE TO THE MACHINE SPINDLE

DIRECTION OF ROTATION SAME AS MACHINE SPINDLE

OFFSET SERIES

AUTOMATIC TOOL CHANGE

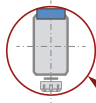

*Min bore for internal machining. Excluding cutting tool

Model	Coolant (options)	TYPE	Rotation	Output	L	Ø min*	Rpm	Nm	ORDER CODE
FR90-10	Water	1	↻	ER16WP Ø1/10	110,5	73	6.000	22	9.FR9.100B0
FR90-13	Water	1	↻	ER20WP Ø1/13	126	88	4.500	40	9.FR9.130B0
FR90-16	Water	2	↻	ER25WP Ø1/16	146,5	98	4.000	80	9.FR9.1600B0
FR90-20	Water	2	↻	ER32WP Ø2/20	153	105	3.500	82	9.FR9.S200B0



Offset series for machining in narrow spaces with coolant input directly from machine spindle and output through the tool at 70BAR

DOUBLE OUTPUT

AUTOMATIC TOOL CHANGE

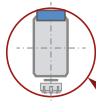

*Min bore for internal machining. Excluding cutting tool

Model	TYPE	Rotation	Output	L	Ø min*	Rpm	Nm	ORDER CODE
F90-7-2U	1	↻↻	ER11 Ø1/7	116	96	10.000	6	9.F90.072U0
F90-7L-2U	1	↻↻	ER11 Ø1/7	176	99	10.000	6	9.F90.072LU0
F90-10-2U	1	↻↻	ER16 Ø1/10	106	131	10.000	11	9.F90.102U0
F90-10L-2U	1	↻↻	ER16 Ø1/10	176	131	10.000	11	9.F90.10L2U0
F9016-2U	2	↻↻	ER25 Ø1/16	100	174	5.000	46	9.F90.162U0
F90-16L-2U	2	↻↻	ER25 Ø1/16	200	175	5.000	46	9.F90.16L2U0
F90-20-2U	1	↻↻	ER32 Ø2/20	108	198	3.500	85	9.F90.202U0
F90-30-2U	3	↻↻	ER40 Ø3/30	115	234	2.500	135	9.F90.302U0



With the double option output you can optimize the production cycle avoiding extra set-up

LIGHT SERIES

AUTOMATIC TOOL CHANGE



Model	Coolant (options)	TYPE	Rotation	Output	L	Ø min*	Rpm	Nm	ORDER CODE
FL90-7	Water	0	↻	ER11 Ø1/7	52	77	8.000	5	9.FL9.07000
FL90-13	Water	1	↻	ER20 Ø1/13	76	122	6.000	20	9.FL9.13000
FL90-16	Water	1	↻	ER25 Ø1/16	76	134	4.000	26	9.FL9.16000
FL90-16-2U	Water	1	↻↻	ER25 Ø1/16	76	180	4.000	26	9.FL9.162U0
FLU-7	Water	0	↻	ER11 Ø1/7	37,5	95	8.000	5	9.FLU.07000

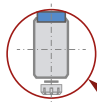

*Min bore for internal machining. Excluding cutting tool



Angle heads with ALLUMINUM body. Weight reduction with same performances and rigidity on compact high speed machining centres.

**INTERCHANGEABLE
DRIVE TAPERS**



EVOLUTION LINE
Modular Angle Heads & Spindle speeders



ATC Series (Automatic Tool Change)

series
SLiM

Ideal for Micromachining in narrow spaces



FS90-3 / FS90-4 / FS90-6							
Model	Coolant (options)	TYPE	Rotation	Output	Nm	Rpm	ORDER CODE
*FS90-3	-	1		6023E Ø1/3	2	8.000	9.FS9.03000
*FS90-4	-	1		600E Ø1/4	3,5	8.000	9.FS9.04000
*FS90-6	-	1		600E Ø1/6	4	8.000	9.FS9.06000

*ALSO AVAILABLE "L" SERIES WITH THE LONGER BODY

series
STD 90°

SMALL angle heads
Ideal for milling, drilling
and tapping at ±90°



F90-7 / F90-10 / F90-13 / F90-16							
Model	Coolant (options)	TYPE	Rotation	Output	Nm	Rpm	ORDER CODE
*F90-7	-	1		ER11 Ø1/7	6	10.000	9.F90.07000
*F90-10	-	1		ER16 Ø1/10	11	10.000	9.F90.10000
*F90-13	-	1		ER20 Ø1/13	27	8.000	9.F90.13000
*F90-16	-	2		ER25 Ø1/16	46	5.000	9.F90.16000
F90-16S	-	1		ER25 Ø1/16	27	8.000	9.F90.16500
F90-20S	-	1		ER36 Ø2/20	46	5.000	9.F90.20S00

*ALSO AVAILABLE "L" SERIES WITH THE LONGER BODY

series
STD 90°

MEDIUM & BIG angle heads
Ideal for milling, drilling
and tapping at ±90°



F90-20 / F90-540							
Model	Coolant (options)	TYPE	Rotation	Output	Nm	Rpm	ORDER CODE
*F90-20	-	2		ER32 Ø2/20	85	3.500	9.G90.20000
F90-540	-	3		ISO40/ CAT/BT40	135	2.500	9.G90.30000

*ALSO AVAILABLE "L" SERIES WITH THE LONGER BODY

series
FMU

Angle heads with ADJUSTABLE
angle from 0° to 90°



FMU-10 / FMU-16 / FMU-20							
Model	Coolant (options)	TYPE	Rotation	Output	Nm	Rpm	ORDER CODE
FMU-10	-	1		ER16 Ø1/10	9	8.000	9.FMU.10000
FMU-16	-	1		ER25 Ø1/16	15	6.000	9.FMU.16000
FMU-20	-	3		ER32 Ø2/20	48	4.000	9.FMU.20000



series
COOLANT

With coolant input from main spindle and output through the tool at 10bar



F90-7L 10bar / F90-10L 10bar / F90-13L 10bar / F90-16L 10bar							
Model	Coolant (options)	TYPE	Rotation	Output	Nm	Rpm	ORDER CODE
*F90-7		1		ER11WP Ø1/7	6	10.000	9.F90.070B0
F90-10		1		ER16WP Ø1/10	11	10.000	9.F90.100B0
F90-13		1		ER20WP Ø1/13	27	8.000	9.F90.130B0
F90-16		2		ER25WP Ø1/16	46	5.000	9.F90.160B0

*ALSO AVAILABLE "L" SERIES WITH THE LONGER BODY

series
COOLANT

With coolant input from main spindle and output through the tool at 10bar



FS90-16S 10bar / F90-20 10bar / F90-540 10 bar							
Model	Coolant (options)	TYPE	Rotation	Output	Nm	Rpm	ORDER CODE
F90-16S		1		ER25WP Ø1/16	27	8.000	9.F90.16S00
F90-20		2		ER32WP Ø2/20	85	3.500	9.F90.200B0
F90-540		3		ISO40/ CAT/BT40	135	2.500	9.F90.540B0

SPINDLE SPEEDERS (Automatic Tool Change)

series
GSS

Spindle speeders designed for milling and drilling operations



GSS10.HS / GSS 13 / GSS 16 / GSS 20 / GSS 26 / GSS 34							
Model	Coolant (options)	TYPE	Rotation	Output	Nm	Rpm	ORDER CODE
GSS 10.HS		1	-	ER16 Ø1/10	3,5	35.000	9.GS.S10HS
GSS 13	-	1	-	ER20 Ø1/13	2,8	22.000	9.GS.S1300
GSS 16	-	2	-	ER25 Ø1/16	7,5	15.000	9.GS.S1600
GSS 20	-	2	-	ER32 Ø2/20	8	12.000	9.GS.S2000
GSS 26		3	-	ER40 Ø3/30	45	10.000	9.GS.S2600
GSS 34		3	-	ER50 Ø3/34	90	8.000	9.GS.S3400

INTERNAL COOLANT FEED THROUGH THE TOOL OPTIONS:
- 10BAR THROUGH ROTATING DISTRIBUTOR
- FROM 30 TO 70BAR THROUGH MACHINE SPINDLE

DIRECTION OF ROTATION OPPOSITE TO THE MACHINE SPINDLE

DIRECTION OF ROTATION SAME AS MACHINE SPINDLE



VDI DIN 69880 (DIN5480)



d1	Coolant	Rotation	ER	H	Nm	Rpm	ORDER CODE
30	Ext.		25	66	32	6000	99.ST.8003
	Int/Ext		25	66	32	6000	99.ST.8011
40	Ext.		32	95	63	6000	99.ST.8005
	Int/Ext		32	95	63	6000	99.ST.8013



d1	Coolant	Rotation	ER	H	Nm	Rpm	ORDER CODE
30	Ext.		25	55	32	6000	99.ST.8030
	Int/Ext		25	55	32	6000	99.ST.8038
40	Ext.		32	100	63	6000	99.ST.8033
	Int/Ext		32	100	63	6000	99.ST.8041

VDI DIN 69880 (DIN5482)



d1	Coolant	Rotation	ER	H	Nm	Rpm	ORDER CODE
30	Ext.		25	94	32	6000	99.ST.8201
	Int/Ext		25	94	32	6000	99.ST.8207
40	Ext.		32	115	63	5000	99.ST.8203
	Int/Ext		32	115	63	5000	99.ST.8209



d1	Coolant	Rotation	ER	H	Nm	Rpm	ORDER CODE
30	Ext.		25	55	32	6000	99.ST.8217
	Int/Ext		25	55	32	6000	99.ST.8223
40	Ext.		32	100	63	5000	99.ST.8220
	Int/Ext		32	100	63	5000	99.ST.8226

VDI DIN 69880 (BARUFFALDI)



d1	Coolant	Rotation	ER	H	Nm	Rpm	ORDER CODE
30	Ext.		25	94	32	6000	99.DP.0903
	Int/Ext		25	94	32	6000	99.DP.0910
40	Ext.		32	115	63	5000	99.DP.0905
	Int/Ext		32	115	63	5000	99.DP.0911



d1	Coolant	Rotation	ER	H	Nm	Rpm	ORDER CODE
30	Ext.		25	55	32	6000	99.DP.0919
	Int/Ext		25	55	32	5000	99.DP.0922
40	Ext.		32	100	63	6000	99.DP.0926
	Int/Ext		32	100	63	5000	99.DP.0928

VDI DIN 69880 (DIN1809)



d1	Coolant	Rotation	ER	H	Nm	Rpm	ORDER CODE
30	Ext.		25	94	32	6000	99.DP.0903
	Int/Ext		25	94	32	6000	99.DP.0910
40	Ext.		32	115	63	5000	99.DP.0905
	Int/Ext		32	115	63	5000	99.DP.0911



d1	Coolant	Rotation	ER	H	Nm	Rpm	ORDER CODE
30	Ext.		25	55	32	6000	99.DP.0919
	Int/Ext		25	55	32	5000	99.DP.0922
40	Ext.		32	100	63	6000	99.DP.0926
	Int/Ext		32	100	63	5000	99.DP.0928

Dmg Mori

NLX: 1500 - 2000 - 2500 - 3000 - 16 Stations - NZX 12 Stations



Coolant	Rotation	ER	H	Nm	Rpm	ORDER CODE
Ext.		32	86,2±89,9	60	10.000	99.MS.G59
Int/Ext		32	86,2±89,9	60	10.000	99.MS.G60
Ext.		40	86,2±89,9	60	10.000	99.MS.G62
Int/Ext		40	88,3±92	60	10.000	99.MS.G63



Coolant	Rotation	ER	H	Nm	Rpm	ORDER CODE
Ext.		32	Max90	60	10.000	99.MS.A72
Int/Ext		32	Max90	60	10.000	99.MS.A73
Ext.		40	90	60	10.000	99.MS.A76
Int/Ext		40	90	60	10.000	99.MS.A77

NZ: 1500 - 2000 - 3100 - 3150 - 3200 - 16 Stations



Coolant	Rotation	ER	H	Nm	Rpm	ORDER CODE
Ext.		25	80,6±84,3	50	12.000	99.MS.A101
Ext.		25	80,6±84,3	50	12.000	99.MS.A102
Ext.		32	85,5±89,2	50	12.000	99.MS.A103
Ext.		32	85,5±89,2	50	12.000	99.MS.A104



Coolant	Rotation	ER	H	Nm	Rpm	ORDER CODE
Ext.		25	85	50	12.000	99.MS.A106
Ext.		25	85	50	12.000	99.MS.A107
Ext.		32	85	50	12.000	99.MS.A108
Ext.		32	85	50	12.000	99.MS.A109

BIGLIA

BMT 40
BMT 55



BMT	Coolant	Rotation	ER	H	Rpm	ORDER CODE
40	Ext.		20	57	6000	99.BG.B40
	Int/Ext		20	57	6000	99.BG.B41
55	Ext.		25	83,5	4000	99.BG.B02.A
	Int/Ext		25	83,5	4000	99.BG.B02.D



BMT	Coolant	Rotation	ER	H	Rpm	ORDER CODE
40	Ext.		32	70	6000	99.BG.B46
	Int/Ext		32	45	6000	99.BG.B47
55	Ext.		32	70	4000	99.BG.B05.A
	Int/Ext		32	70	4000	99.BG.B06.B

NAKAMURA

BMT 44: WT100 - TW1
BMT 55: Super NTJ-NTJX / NTM 3 / TMC 18 / TW 10 / SC 150-250 / WT 150-250 / WTW 150 / WTS 150 / WT 100



BMT	Coolant	Rotation	ER	H	Nm	Rpm	ORDER CODE
44	Ext.		25	Max 57,2	32	6000	99.NK.A40
	Int/Ext		25	Max 57,2	32	6000	99.NK.A43
55	Ext.		32	68,5±72,2	63	6000	99.NK.A03
	Int/Ext		32	68,5±72,2	63	6000	99.NK.A04



BMT	Coolant	Rotation	ER	H	Nm	Rpm	ORDER CODE
44	Ext.		25	60	32	6000	99.NK.A50
	Int/Ext		25	60	32	6000	99.NK.A53
55	Ext.		32	55	63	6000	99.NK.A13
	Int/Ext		32	55	63	6000	99.NK.A14

Upgrade your lathe & boost productivity

More than 700 models available with the best price / quality ratio



HAAS (VDI40)

Interchangeable couplings for the different HAAS turret



Coolant	Rotation	ER	H	H1	Nm	Rpm	ORDER CODE
Ext.		32	75	117,5	63	6000	99.HA.590082
Int/Ext		32	75	117,5	63	6000	99.HA.590082B
Ext.		32	75	104,8	63	6000	99.HA.590083
Int/Ext		32	75	104,8	63	6000	99.HA.590083B
Ext.		32	75	130,25	63	6000	99.HA.596352
Int/Ext		32	75	130,25	63	6000	99.HA.596352B

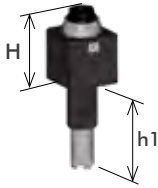

Coolant	Rotation	ER	H	H1	Nm	Rpm	ORDER CODE
Ext.		32	75	117,5	63	6000	99.HA.590084
Int/Ext		32	75	117,5	63	6000	99.HA.590084B
Ext.		32	75	104,8	63	6000	99.HA.590085
Int/Ext		32	75	104,8	63	6000	99.HA.590085B
Ext.		32	75	130,25	63	6000	99.HA.596353
Int/Ext		32	75	130,25	63	6000	99.HA.596353B



MAZAK

QTN2 Quick turn nexus QTN 200/500 - Super quadrex turn SQT 15/18 - 200/250

Coolant	Rotation	ER	H	Nm	Rpm	ORDER CODE
Ext.		32	116,2÷120	80	6000	99.MZ.A58
Int/Ext		32	116,2÷120	80	6000	99.MZ.A59

Coolant	Rotation	ER	H	Nm	Rpm	ORDER CODE
Ext.		32	130	80	6000	99.MZ.A65
Int/Ext		32	130	80	6000	99.MZ.A66



MAZAK (Smart)

SMART QTS Quick turn smart QTS 100M/200M - QT COMPACT 100M - 200M - 300M

Coolant	Rotation	ER	H	Nm	Rpm	ORDER CODE
Ext.		32	Max 70	60	6000	99.MZ.A03
Int/Ext		32	Max 70	60	6000	99.MZ.A06

Coolant	Rotation	ER	H	Nm	Rpm	ORDER CODE
Ext.		32	80	60	6000	99.MZ.A09
Int/Ext		32	80	60	6000	99.MZ.A10



OKUMA

BMT 60: Space turn LB200EX - LB2500EX - LB3000EX - Genos Series L300-MW
Mulus U3000 - U4007 - LU3000EX M - MY

BMT	Coolant	Rotation	ER	H	Nm	Rpm	ORDER CODE
60	Ext.		32	Max 79	60	6000	99.OK.A80
	Int/Ext		32	Max 79	60	6000	99.OK.A81

BMT	Coolant	Rotation	ER	H	Nm	Rpm	ORDER CODE
60	Ext.		32	70	60	6000	99.OK.A82
	Int/Ext		32	70	60	6000	99.OK.A83



TSUGAMI

BMT 65: M06D - M06SD - M06SY - M08D - M08SD - M08SY

Coolant	Rotation	ER	H	Nm	Rpm	ORDER CODE
Ext.		25	60	40	8000	99.TS.A01
Int/Ext		25	60	40	8000	99.TS.A02

Coolant	Rotation	ER	H	Nm	Rpm	ORDER CODE
Ext.		25	60	40	8000	99.TS.A08
Int/Ext		25	60	40	8000	99.TS.A09



MIYANO

Ø45: ABX 51/64 TH2/TH3 - BNE 34/42 - BNJ 42/51

Ø54: ABX 51/64 THY - ABX 51/64 SY

BMT	Coolant	Rotation	ER	H	Nm	Rpm	ORDER CODE
45	Ext.		25	53,9÷57,6	35	6000	99.MY.A02
	Int/Ext		25	53,9÷57,6	35	6000	99.MY.A03
54	Ext.		32	75,7÷79,4	60	6000	99.MY.A09
	Int/Ext		32	75,7÷79,4	60	6000	99.MY.A10

BMT	Coolant	Rotation	ER	H	Nm	Rpm	ORDER CODE
45	Ext.		25	65	35	6000	99.MY.A05
	Int/Ext		25	65	35	6000	99.MY.A06
54	Ext.		32	93,9	60	6000	99.MY.A11
	Int/Ext		32	93,6	60	6000	99.MY.A12



BMT 45/55/65/75

Doosan - Hardinge - Samsung - Haas - Hwacheon - Hyundai WIA - Victor

BMT	Coolant	Rotation	ER	H	Nm	Rpm	ORDER CODE
45	Ext.		25	Max 57.2	35	8000	99.DS.A03
	Int/Ext		25	Max 57.2	35	8000	99.DS.A04
55	Ext.		25	Max 57.2	40	8000	99.DS.A01
	Int/Ext		25	Max 57.2	40	8000	99.DS.A02
65	Ext.		32	Max 72.5	70	6000	99.DS.A41
	Int/Ext		32	Max 72.5	70	6000	99.DS.A42
75	Ext.		40	Max 90.2	100	6000	99.DS.A34
	Int/Ext		40	Max 90.2	100	6000	99.DS.A35



BMT	Coolant	Rotation	ER	H	Nm	Rpm	ORDER CODE
45	Ext.		25	65	35	8000	99.DS.A07
	Int/Ext		25	65	35	8000	99.DS.A08
55	Ext.		25	70	40	8000	99.DS.A11
	Int/Ext		25	70	40	8000	99.DS.A12
65	Ext.		32	72	70	6000	99.DS.A51
	Int/Ext		32	72	70	6000	99.DS.A52
75	Ext.		40	60	100	6000	99.DS.A38
	Int/Ext		40	60	100	6000	99.DS.A39



DIRECTION OF ROTATION SAME AS MACHINE SPINDLE

DIRECTION OF ROTATION OPPOSITE TO THE MACHINE SPINDLE

ACCURACY and RELIABILITY GUARANTEED FOR 2 YEARS!!

A wide range of driven tools in order to equip the CNC lathes and turrets of the most popular builders on the market with an unbeatable price/quality ratio.

QUICK AND NO-EXPENSIVE ASSISTANCE BY OUR TECHNICAL EXPERTS !

■ MAIN BODY

Specially treated corrosion resistant integral steel body with new design to improve rigidity and reduce vibrations.

■ INTERNAL COOLANT

All the driven tools can be supplied with internal coolant option up to 100bar. Dry running possible!

■ TORQUE & RPM

Rated to 100 Nm torque and 10.000Rpm.

■ OUTPUTS

ER collets / WELDON / HSK / CAT / SK / BT / CAPTO or shell end milling cutter.

■ GLEASON GEARS

Gleason spiral bevel gears with ground teeth in order to guarantee a bigger torque, less noise and heating.

■ BEARINGS

Angular contact, preloaded, high precision ball bearings + tape roller bearings on output spindle for better rigidity and longer life.

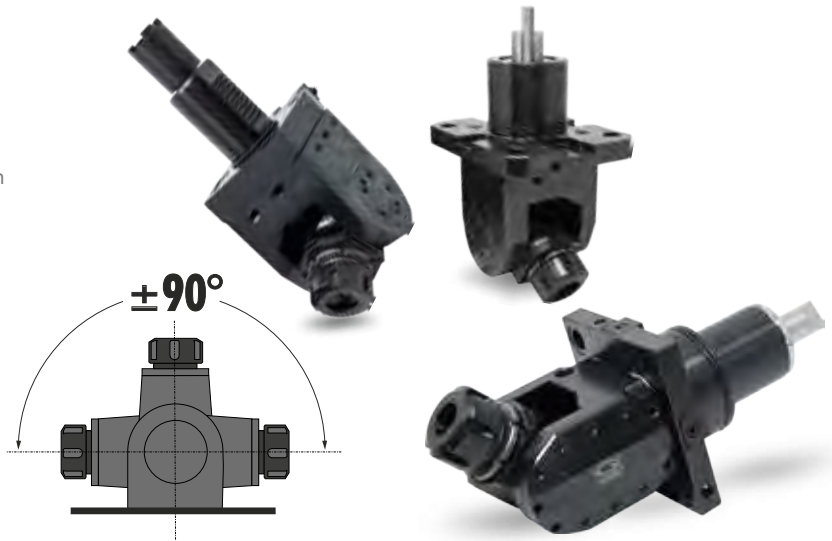

Options:



INTERNAL COOLANT



HIGHER SPEED
Up to 10.000 Rpm



COMPENSATED COLLETS



MODULAR QUICK CHANGE

MIYANO

Ø45: ABX 51/64 TH2/TH3 - BNE 34/42 - BNJ 42/51

Ø54: ABX 51/64 THY - ABX 51/64 SVY



Ø	ER	Coolant	Rotation	H	Nm	Rpm	ORDER CODE
45	20	Ext.		65	15	6000	99.MY.A08
	20	Int/Ext		65	15	6000	99.MY.A13
54	20	Ext.		75	15	6000	99.MY.A19
	20	Int/Ext		75	15	6000	99.MY.A20

NAKAMURA

BMT 44 - WT100 -TW1

BMT 55 - SUPER NTJ-NTJX / NTM 3 / TMC 18 / TW10 / SC150-250 / WT150-250 / WTW 150 / WTS 150 / WT100



BMT	Coolant	Rotation	ER	H	Nm	Rpm	ORDER CODE
44	Ext.		16	68,5	10	6000	99.NK.A59
	Int/Ext		16	68,5	10	6000	99.NK.A69
55	Ext.		20	71	15	6000	99.NK.A22
	Int/Ext		20	71	15	6000	99.NK.A32
65	Ext.		25	80	25	6000	99.NK.A82

TSUGAMI

BMT 55 M06D / M06SD / M06SY /

M08D / M08SD / M08SY



ER	Coolant	Rotation	H	Nm	Rpm	ORDER CODE
20	Ext.		65	15	8000	99.TS.A24
20	Int/Ext		65	40	8000	99.TS.A25

BMT

BMT 45 - 55 - 65 - 75



BMT	Coolant	Rotation	ER	H	Nm	Rpm	ORDER CODE
45	Ext.		20	65	15	8000	99.DS.A16
	Int/Ext		20	65	15	8000	99.DS.A17
55*	Ext.		20	65	15	8000	99.DS.A23
	Int/Ext		20	65	15	8000	99.DS.A66
65*	Ext.		25	75	25	6000	99.DS.A64
	Int/Ext		25	75	25	6000	99.DS.A65
75	Ext.		25	75	25	6000	99.DS.A47
	Int/Ext		25	75	25	6000	99.DS.A48

ORIENT YOURSELF BETTER!!!

ADJUSTABLE
Adjustable Driven Tools ±90°



ACCURACY and RELIABILITY GUARANTEED FOR 2 YEARS!!

VDI DIN 69880 (DIN5480)



D1	ER	Coolant	Rotation	H	Nm	Rpm	ORDER CODE
30	20	Ext.		64	15	6000	99.ST.8087
	20	Ext.		97	15	6000	99.ST.8088
	20	Int/Ext		64	15	6000	99.ST.8091
	20	Int/Ext		97	15	6000	99.ST.8092
40	25	Ext.		81	25	4000	99.ST.8089
	25	Int/Ext		81	25	4000	99.ST.8093
50	40	Ext.		123	50	4000	99.ST.8090



VDI DIN 69880 (DIN5482)



D1	Coolant	Rotation	ER	H	Nm	Rpm	ORDER CODE
30	Ext.		20	64	15	6000	99.ST.8248
	Ext.		20	97	15	6000	99.ST.8249
	Int/Ext		20	97	15	6000	99.ST.8254
40	Ext.		25	81	25	5000	99.ST.8250
	Int/Ext		25	81	25	5000	99.ST.8255
50	Ext.		25	100	25	4000	99.ST.8251



VDI DIN 69880 (Baruffaldi)



D1	ER	Coolant	Rotation	H	Nm	Rpm	ORDER CODE
30	20	Ext.		64	15	6000	99.BE0051
	20	Ext.		97	15	6000	99.BE0052
	20	Int/Ext		64	15	6000	99.BE0054
	20	Int/Ext		97	15	6000	99.BE0055
40	25	Ext.		81	25	5000	99.BE0053
	25	Int/Ext		81	25	5000	99.BE0056



VDI DIN 69880 (DIN1809)



D1	Coolant	Rotation	ER	H	Nm	Rpm	ORDER CODE
30	Ext.		20	64	32	6000	99.DP.0940
	Ext.		20	97	32	6000	99.DP.0941
	Int/Ext		20	64	63	6000	99.DP.0943
	Int/Ext		20	97	63	6000	99.DP.0944
40	Ext.		25	81	32	5000	99.DP.0942
	Int/Ext		25	81	32	5000	99.DP.0945



BIGLIA

BMT 40 - 55



BMT	Coolant	Rotation	ER	H	Nm	Rpm	ORDER CODE
40	Ext.		11	91,5	-	6000	99.DS.A16
	Ext.		16	105	-	6000	99.DS.A23
55	Ext.		20	140	-	4000	99.DS.A64
	Ext.		16	111	-	4000	99.DS.A47



DMG MORI

NLX - NZX - NZ - SL - ZL - DL



	Coolant	Rotation	ER	H	Nm	Rpm	ORDER CODE
NLX	Ext.		25	78	25	10000	99.MS.A86
	Int/Ext		25	78	25	10000	99.MS.A87
NZ	Ext.		20	50	17	12000	99.MS.A118
	Int/Ext		20	50	17	12000	99.MS.A119
SL ZL DL	Ext.		20	66	25	6000	99.MS.A55
	Int/Ext		20	66	25	6000	99.MS.A56



HAAS

VDI 40

Interchangeable couplings for the different HAAS turret



ER	Coolant	Rotation	H	h1	Nm	Rpm	ORDER CODE
25	Ext.		81	104,8	63	6000	99.HA.00U1
25	Int/Ext		83	104,8	63	6000	99.HA.00U1B
25	Ext.		81	117,55	25	5000	99.HA.00U2
25	Int/Ext		81	117,55	25	5000	99.HA.00U2B
25	Ext.		81	130,25	25	6000	99.HA.00U3
25	Int/Ext		81	130,25	25	6000	99.HA.00U3B



MAZAK

QTN1 - QTN2 - QTN3 - QTS



D1	Coolant	Rotation	ER	H	Nm	Rpm	ORDER CODE
QTN1	Ext.		20	85	63	6000	99.MZ.A56
	Int/Ext		25	85	80	6000	99.MZ.A74
QTN2	Int/Ext		25	85	80	6000	99.MZ.A64
	Ext.		32	85	100	4000	99.MZ.A80
QTS	Ext.		25	80	30	6000	99.MZ.A14
	Int/Ext		25	80	30	6000	99.MZ.A15



DIRECTION OF ROTATION OPPOSITE TO THE MACHINE SPINDLE

DIRECTION OF ROTATION SAME AS MACHINE SPINDLE

Right Hand Radial Holder

DIN 69880 VDI B1



VDI	ORDER CODE
30	T.B1-30x20x40
40	T.B1-40x25x44
50	T.B1-50x32x55
60	T.B1-60x32x60

Right Hand Radial Holder*

DIN 69880 VDI B3



*Upside down

VDI	ORDER CODE
30	T.B3-30x20x40
40	T.B3-40x25x44
50	T.B3-50x32x55
60	T.B3-60x32x60

Multi-Seat Holder

DIN 69880 VDI D1



VDI	ORDER CODE
30	T.D1-30x20x60
40	T.D1-40x25x72
50	T.D1-50x32x85
60	T.D1-60x32x110

Left Hand Radial Holder

DIN 69880 VDI B2



VDI	ORDER CODE
30	T.B2-30x20x40
40	T.B2-40x25x44
50	T.B2-50x32x55
60	T.B2-60x32x60

Left Hand Radial Holder*

DIN 69880 VDI B4



*Upside down

VDI	ORDER CODE
30	T.B4-30x20x40
40	T.B4-40x25x44
50	T.B4-50x32x55
60	T.B4-60x32x60

Multi-Seat Holder

DIN 69880 VDI D2



*Upside down

VDI	ORDER CODE
30	T.D2-30x20x60
40	T.D2-40x25x72
50	T.D2-50x32x85
60	T.D2-60x32x110

VDI Blank

DIN 69880 VDI A1



VDI	ORDER CODE
30	T.A1-30x85
40	T.A1-40x100
50	T.A1-50x125
60	T.A1-60x160

Right Hand Axial Holder

DIN 69880 VDI C1



VDI	ORDER CODE
30	T.C1-30x20x70
40	T.C1-40x25x85
50	T.C1-50x32x100
60	T.C1-60x32x125

Left Hand Axial Holder

DIN 69880 VDI C2



VDI	ORDER CODE
30	T.C2-30x20x70
40	T.C2-40x25x85
50	T.C2-50x32x100
60	T.C2-60x32x125

VDI Blank

DIN 69880 VDI A2



VDI	ORDER CODE
30	T.A2-30x85
40	T.A2-40x100
50	T.A2-50x125
60	T.A2-60x160

Indexable Drill Holder

DIN 69880 VDI E1



*please specify diameter when ordering

VDI	Size Range	ORDER CODE
30	Ø16-40	T.E1-30x.....*
40	Ø16-50	T.E1-40x.....*
50	Ø16-50	T.E1-50x.....*
60	Ø16-50	T.E1-60x.....*

Boring Bar Holder

DIN 69880 VDI E2



*please specify diameter when ordering

VDI	Size Range	ORDER CODE
30	Ø6-40	T.E2-30x.....*
40	Ø6-50	T.E2-40x.....*
50	Ø8-50	T.E2-50x.....*
60	Ø16-50	T.E2-60x.....*

**MAX PRECISION
FOR YOUR LATHE**

ER Collet Chuck

DIN 69880 VDI E4



VDI	ER	ORDER CODE
30	16	T.E4-3016
30	25	T.E4-3025
30	32	T.E4-3032
30	40	T.E4-3040
40	25	T.E4-4025
40	32	T.E4-4032
40	40	T.E4-4040
50	25	T.E4-5025
50	32	T.E4-5032
50	40	T.E4-5040
60	32	T.E4-6032
60	40	T.E4-6040

Morse Taper Chuck

DIN 69880 VDI F



VDI	Morse Taper	ORDER CODE
30	1	T.VDI30MK1
30	2	T.VDI30MK2
30	3	T.VDI30MK3
40	1	T.VDI40MK1
40	2	T.VDI40MK2
40	3	T.VDI40MK3
40	4	T.VDI40MK4
50	2	T.VDI50MK2
50	3	T.VDI50MK3
50	4	T.VDI50MK4
50	5	T.VDI50MK5
60	2	T.VDI60MK2
60	3	T.VDI60MK3
60	4	T.VDI60MK4
60	5	T.VDI60MK5

Tension & Compression Tap Chuck

DIN 69880 VDI GML



VDI	Adaptor Size	ORDER CODE
30	1	T.VDI30GR1
30	2	T.VDI30GR2
40	1	T.VDI40GR1
40	2	T.VDI40GR2

Right Hand Part Off Holder

DIN 69880 VDI AR



VDI	Blade	ORDER CODE
30	26	T.AR-3026
30	32	T.AR-3032
40	26	T.AR-4026
40	32	T.AR-4032

Right Hand Part Off Holder*

DIN 69880 VDI ARU



*Upside down

VDI	Blade	ORDER CODE
30	26	T.ARU-3026
30	32	T.ARU-3032
40	26	T.ARU-4026
40	32	T.ARU-4032

Left Hand Part Off Holder*

DIN 69880 VDI AL



*Upside down

VDI	Size Range	ORDER CODE
30	26	T.AL-3026
30	32	T.AL-3032
40	26	T.AL-4026
40	32	T.AL-4032



1	Shank tolerance IT6 (H6)
2	Hardened to HRc58 all over
3	Internal diameters, shank and teeth completely ground finish

Bar Puller

DIN 69880 VDI SG



VDI	ORDER CODE
30	T.VDI30-BP10-75
40	T.VDI40-BP10-75
50	T.VDI50-BP10-75

VDI Steel Turret Cap

DIN 69880 VDI



VDI	ORDER CODE
30	T.VDI 30 - AC
40	T.VDI 40 - AC
50	T.VDI 50 - AC
60	T.VDI 60 - AC

VDI Plastic Turret Cap

DIN 69880 VDI



VDI	ORDER CODE
30	T.VDI 30 - PL
40	T.VDI 40 - PL
50	T.VDI 50 - PL
60	T.VDI 60 - PL

Bespoke Workholding

Bespoke Design

Because of Gerardi's huge range of standard parts, bespoke work holding solutions can be designed quickly, usually within 48 hours. Designs can be tailored to suit any machine tool and budget with different options for the end user.

Bespoke Manufacturing

All Gerardi bespoke workholding comes with the same quality and precision of the standard ranges including 20 microns ground working surfaces, jaws/bases hardened to HRc60 and a 5 year warranty.



Standard vise Art.1 with machineable jaws mounted on vertical machining center



Application of evolution angle head F90-20 10bar mounted on vertical machining center

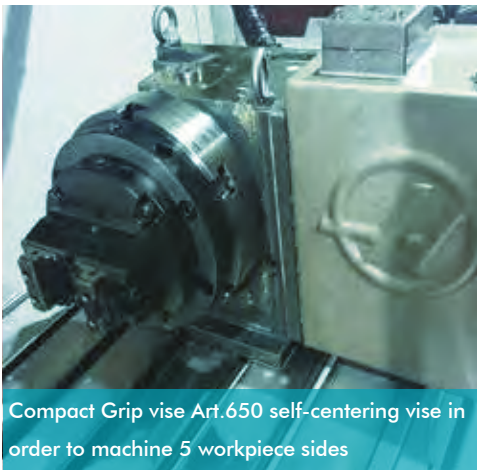

Compact Grip vise Art.650 self-centering vise in order to machine 5 workpiece sides



FMS vise with machineable jaws for specific workpieces clamping



CompactGRIP vise Art.650 with riser mounted on a 5 axis machine

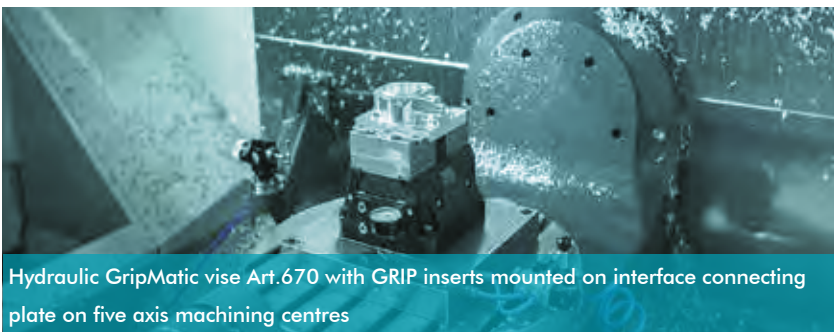

Hydraulic GripMatic vise Art.670 with GRIP inserts mounted on interface connecting plate on five axis machining centres



HAAS lathe ST20Y machine with Gerardi radial driven tools equipment

GERARDI SPA

via Giovanni XXIII, 101
21015 LONATE POZZOLO (VA) Italia
Tel. +39.0331.303911 - Fax
+39.0331.301534

gerardi@gerardispa.com
www.gerardi.it

Distributed by: